

TOTAL AMIGA

Summer 2003
Issue 15

Key Features

Works on OCS, ECS, AGA and
based Amigas and compatibles.

Smoothly scrolls animations, graphics
text.

Over 150 powerful functions.

50plus cool transition effects - view
screens and objects.

Plays back music modules and
to accompany your application.

Delivered on CD-ROM with
examples.



Hollywood

Become an ace director
with our in-depth tutorial.

AmigaOS 4.0

The latest screen-shots and news.

Pegasos & MorphOS

Get the lowdown on this alternative
PPC system and OS from our
detailed review.



£4.00
8.00Euro

For Amigans, By Amigans, On Amigas!

TOTAL AMIGA

Issue 15

Summer 2003

Contents

News

Editorial2
News Items3
Fleecy Moss Column8
Buzz Word.....8
Alan Redhouse Column.....9
AmigaOS 4 Update 10

Features

Selling the New Amiga.... 12
"it's not about the desktop!" 14
Introduction to AROS..... 16
Mac: Reloaded..... 18
Quake II Competition 21
Tales of Tamar Update 42

Reviews

Pegasos and MorphOS .. 22
IBrowse 2.3 28
fxPaint 2.0 32
Aqua..... 35
Subway USB 36
PD Paradise 38

Support

Top Tips..... 44
Hollywood Tutorial..... 46
Mailing Lists 51
Next Issue 51
Colour Screenshots etc. ... 52

Advertisers

Amiga Inc. 20
AmigaWorld.net..... 15
Eyeteck 26 and 27
Fore-matt Home Computing 43
Kicksoft 31 and 41
Livewire 37

Editorial

Welcome to another issue of Total Amiga. I can't help but start by saying that, I think this is one of the best issues we have ever produced both in content and quality.

The best place to start has to be introducing you to our three new writers (I expect all of them will be familiar to you). First we have John Chandler who wrote for Amiga Active and more recently has published a regular Amiga column on suite101.com.

There are many reasons why it's great to have these professional writers on board, and it's not just that each one of them has written a fine piece for this issue. Firstly, with their broader knowledge of the computing world, both Andrew and John have been able to comment on where Amiga fits in and what opportunities present themselves - a topic we've not really been able to cover before.

Andrew and Richard have been able to give us lots of tips on enhancing the magazine and have cast their eyes over some of the copy. We hope you'll notice some changes for the better in this issue, and there are more to come in the future.

I should also mention that equally important to Total Amiga are contributions from readers. In this issue Jonathan Haddock has submitted a review of his Subway USB card, and I know he has several more reviews up his sleeve for issue 16.

If you've read the last few issues of Total Amiga or keep up with the news web sites you will have heard a great deal about MorphOS and the Pegasos PPC computer. Until now, apart from a brief look at WoASE last year, none of the Total Amiga team had actually used a Pegasos in anger.

After a few fairly quiet months the wraps seem to be coming off AmigaOS 4. While it has not been released yet, we at least know Workbench and legacy applications are running on the new kernel.

progress) and showing the anti-aliased font display. John Chandler has written a round up of the latest news on page 10, and you can see some of the screen-shots in colour on the back cover.

If you bought Hollywood after our review in the last issue or are just interested in this powerful multimedia application be sure to have a go at my tutorial on page 46. I designed it to get you started with a simple presentation (which you can customise with your own graphics and text) and as a launch pad for more complex multimedia applications.

For this issue we have a particularly large number of supporting files on the web site. There are additional links for the Mac emulation feature, links for the MorphOS review and the files needed for the Hollywood tutorial. Also for the Hollywood tutorial we have a compiled executable of the presentation you can download and play even if you don't own Hollywood yourself.

http://www.totalamiga.org/issue15.html

Well that's all I have space for. Enjoy the magazine, and I look forward to hearing your comments and suggestions.

Robert Williams editor@totalamiga.org

About Total Amiga

Total Amiga is published quarterly by South Essex Amiga Link. For subscription details contact us at the address below or our website.

Editor: Robert Williams
Design: Robert Williams
Contributors: Sam Byford, Michael Carrillo, John Chandler, Richard Drummond, Jonathan Haddock, Andrew Korn, Fleecy Moss, Mick Sutton

Proofreading: Sean Courtney, Mick Sutton and the contributors

Contact Us

If you have any queries suggestions or want to contact us for any reason please use one of the following:

Email: editor@totalamiga.org
WWW: http://www.totalamiga.org/
Post: Total Amiga, 26 Wincoat Drive, BENFLEET, Essex, SS7 5AH, UK.

Telephone: +44 (0) 1268 569937 (19:00 - 22:00 UK time only please)

Only Amiga Software Made it Possible

Total Amiga is designed and laid out using:

Hardware: Home built x86 PC, AMD Athlon XP 2000+, nVidia GeForce 2 MX400, 256Mb RAM, 40Gb HDD.
Software: Amithlon by Bernie Meyer et. al, Amiga OS 3.9 by Amiga, PageStream 4.1 by Softlogik, TypeSmith 2.5 by Softlogik, ImageFX 4.5 by Nova Design, Photogenics 5 by Paul Nolan

Exploring the Zone

It's been a while since we've seen any new fractal generation software. In reports from recent Amiga shows you may have noticed a stand covered with stunning fractal images. This stand belongs to Elena Novaretti and the fractals are produced using her own custom software.

The great news is that Elena has just released her fractal generator to the public as Zone Explorer. If you know what you are doing you can create your own formulae as external modules in C or assembler. However for those of us without the necessary mathematical knowledge a large number of examples are supplied and you can easily tweak parameters to get different effects.



Here are some other key features:

- Easy to use interface - explore any formula with a few clicks.
• Switch between Julia, Mandelbrot and "Generalised" Mandelbrot mapping for the same formula.
• Multitasking - open multiple windows and alter parameters while images are being calculated.
• Optional antialiasing - for even higher quality output and more apparent detail.
• Independent render to create high resolution output (useful for prints etc.)

Zone Explorer is supplied with executables for classic 68K Amigas and emulators such as Amithlon and PPC native for MorphOS. The program is freeware and can be downloaded from: http://www.elena-fractals.it



AmiZilla

Want to help bring Mozilla, the well-known open-source web browser suite, to the Amiga? Well now you can contribute to a new effort to get the browser ported. Bill Panagouleas of DiscreetFX has started the AmiZilla effort which aims to collect a prize fund that will be donated to the first programmer or team to demonstrate a working Mozilla port.

Mozilla is a suite of Internet tools, its main component being a fully-featured browser, which was initially based on the source code released by Netscape in

1998. Mozilla is an open-source effort contributed to by a large number of programmers. The suite has been ported to numerous operating systems including Windows, MacOS X and Linux. From an Amiga user's point of view it has the advantage of support for more modern standards such as Cascading Style Sheets and DHTML.

At the time of writing (mid-June) the total fund had risen to over 4000 USD with donations from a number of Amiga companies, user groups and individual users. You can donate to the prize fund on the AmiZilla web site using PayPal, and there is a mailing list for potential developers to discuss ideas and form a team.

Legalese

The views expressed in this magazine are those of the author of each piece, they do not necessarily reflect the views of the editor, other contributors or SEAL.

Please Note: Total Amiga is produced by the editor and contributors in their spare time. While we always strive to produce the magazine on time and include all the advertised contents this is not always possible due to other commitments. The price you pay for Total Amiga covers our costs and nothing more, we don't make a profit from it.

If you wish to contact a contributor please send your message to one of the addresses in this section and we will pass it on.

Amiga is a registered trademark and the Amiga logo, the "Boing Ball" device, AmigaDOS, Amiga Kickstart, Amiga Workbench, Autoconfig, Bridgeboard, and Powered by Amiga are trademarks of AMIGA Inc. All other trademarks mentioned are the property of their respective owners.

Will Algor be a Winner? OS4 in a Flash

German hardware manufacturer E3B has been hard at work again to bring out yet another new product. Lame jokes about presidential hopefuls aside, the Algor Zorro USB card builds on the success of the Highway (the first Zorro USB card, reviewed in Total Amiga issue 13) with enhanced performance and new features.

Algor uses a new USB controller chip that incorporates more of the USB protocol in hardware reducing the amount of work that has to be done by the software drivers. While the Algor is still a USB 1.1 host (USB 2.0 devices are supported but not in their high-speed mode) it can achieve significantly higher transfer rates across the USB bus than the Highway while the drivers use less CPU time. For example, in benchmarks on an A4000 with an 060 accelerator carried out by E3B, a Lacie media card reader achieved 491Kb per second on the Highway and 926Kb/s on the Algor. The card has three

USB ports that are mounted on two back plates; the plate containing a single USB port also has a cut out for the Ethernet connection of E3B's Norway 10BaseT Ethernet card. The Algor retains the expansion connector of the Highway, hence the Norway is compatible, but it does not have a clock port.

The other new feature of the Algor is 512Kb of Flash ROM; this allows the storage of system modules which are then available during boot up. The main use for this ROM is to enable the Poseidon USB stack and class drivers to be available as soon as the computer is

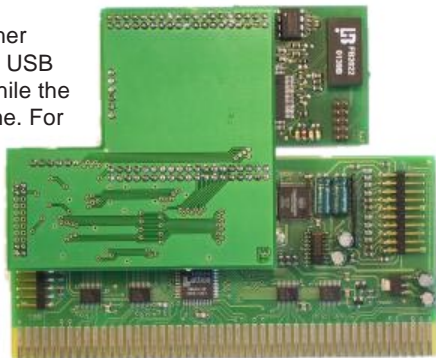

A Highway with ROMulus (L shaped) and Norway attached.

switched on. This feature enables the system to boot from a USB mass storage device and, with AmigaOS 3.9, USB mice and keyboards to be used in the early start-up menu. E3B and Hyperion have also announced that the Flash ROM on the Algor and ROMulus will be supported by AmigaOS 4 to speed boot-up on classic Amiga systems with PPC accelerators (see our KickFlash OS4 news item for more information). Highway owners will be pleased to hear that they don't have to replace their card to get the ROM functionality. The ROMulus add on we mentioned last issue is now in production at E3B. If you don't require USB note that Elbox and Individual computers have also announced Flash ROM cards for OS 4.

The Algor is available now and costs 114.95 Euro (about £85). Detailed specifications and other information can be found on the E3B web site: <http://www.e3b.de>

The main distributor of E3B products is KDH Datentechnik: <http://www.kdh-shop24.de>

Another Hollywood Blockbuster

It's been a while since the announcement of Hollywood 1.5 that we reported in issue 14, however by the time you read this the new version of the multimedia application layer (reviewed in issue 13) should be available. The reason for the delay is that many additional features have been added to the upgrade. Due to the amount of work AirsoftSoftwair are making a charge for this upgrade.

Hollywood's scripting language is now much more powerful and



A demo-style text scroller.

the program has many more features and effects. Some of the key additions include:

- Multiple graphics layers.
- Off-screen rendering.
- Control of layer position, size and transparency.
- Over 50 new transition effects (making over 100 in total).
- Image processing effects including rotation, scaling, axis flipping, texturing, lighten, darken, and many more.
- Retargetable via AHI for all sound effects and music.
- Dynamic window transparency.
- Joystick support.

The program is supplied on CD-ROM and many example scripts have been added to demonstrate the new features. A full copy of Hollywood 1.5 supplied on CD costs 55 US Dollars. An upgrade



A Scala demo loaded via Malibu.

from version 1.0 is available at 22 Dollars.

At the same time as the Hollywood 1.5 release the first plug-in for the program is also available. Malibu allows the import of Scala presentations into Hollywood. Unless you've joined the Amiga scene very recently you'll know that Scala was the premier multimedia package for many years but sadly does not support graphics cards. Once loaded into Hollywood, via Malibu, Scala presentations can be displayed on all devices supported by Hollywood, including, of course,

With the announcement of several Flash ROM solutions in recent weeks, Amiga users can look forward to a return to quick-booting Kickstarts. Since the release of OS 3.5 we have become used to one or more reboots when starting our machines, and although OS 4.0 has a new Kickstart it won't be supplied on ROM as standard. Elbox, E3B and Individual computers are all planning additions with a Flash ROM to hold Kickstart 4.0 when OS 4 is installed on a classic Amiga with a PowerPC accelerator.

The Individual Computers product is a new Zorro card, called the KickFlash OS4. It is fitted with a minimum of 1Mb of Flash ROM to hold the updated Kickstart for OS 4. An image of the new Kickstart will be loaded from the ROM removing the need for a reboot and significantly reducing boot time. The KickFlash OS4 is also upgradable and can handle up to 1Gb of Flash ROM; potentially allowing the entire operating system to be located in ROM. Elbox and E3B are also producing cards with Flash ROMs; we cover these in other news items this issue.

KickFlash OS4 is expected to be available in time for the OS 4 release and will cost 34.90 Euro (about £25), for further details visit Individual Computers at: <http://www.ami.ga>

on graphics cards. The Malibu plug-in costs 29 Dollars alone and is also available as a bundle with Hollywood 1.5 (full version or upgrade).

A plug-in (code named Pasedena) to allow Hollywood to display Power Point files is also in development. Given the popularity of Microsoft's presentation program in companies and institutions this could be a god send for Amigans who use their Amiga for business or academic work.

All of these products can be ordered direct from Airsoft-Softwair on their web site at: <http://www.airsoftsoftwair.com>

Here Comes a Spider

A new version of the Spider USB PCI card has been released by Elbox for use in their Mediator PCI bus boards. The card is similar to the original Spider in that it has five USB ports (four external and one internal) and supports USB 1.1 and USB 2.0 including high-speed mode. USB 2.0 high-speed can transfer data at a theoretical maximum of 480MB/s (megabits per second) with a compatible device compared to the 12MB/s of USB 1.1 full speed. The Spider II is based on an updated NEC USB chipset that is said to improve data transmission by up to 20 percent. Most interestingly though is the fact that Elbox have added support for Amithlon to their Spider hardware driver. This means you can plug a Spider II into your an x86 PC and utilise the USB ports within the Amithlon emulation -

bringing USB support to Amithlon for the first time. The PCI card can also be used under other operating systems running on the PCI but you will have to locate suitable drivers yourself. Expect a short review of the Spider under Amithlon in the next issue of Total Amiga.

The Spider II is available direct from Elbox (<http://www.elbox.com>) for 49.95 Euro plus shipping. Power Computing is the UK distributor for Elbox and they sell the Spider II for £49.95, contact Power at: <http://www.powerc.com> +44 (0)1234 851 500

To use the card you also need to purchase a keyfile for the Poseidon USB stack (used by the Elbox driver), this is available on-line from IOSpirit (<http://www.iospirit.com>) and costs 19.99 Euro (£15 approx.)



Elbox have also announced two Flash ROM products that will enable booting from USB devices connected to a Spider card and allow AmigaOS 4 to boot more quickly on classic Amigas with PPC accelerators (see our KickFlash OS4 news item for more information). The eFlash 4000 is a Zorro III card and the eFlash 1200 is for the PCMCIA slot, both contain 1Mb of FlashROM. The eFlash 4000 is expected to be available in July at a price of 39.95 Euro and the A1200 version is due in August priced at 29.95 Euro.

Pegasos II: The Price is Right

Genesi have announced the pricing of the forthcoming Pegasos II and the availability of the the final batch of Pegasos I motherboards through selected retailers. The Pegasos II is Genesi's next-generation PowerPC motherboard and, as yet, few details of the final specification are available. However we do know it is based on a Marvell north bridge chip providing up to three gigabit Ethernet ports and support for DDR (double data rate) memory. The Pegasos II will use the same PowerPC CPU cards as the Pegasos I; the image accompanying this news item is one of the first G4 Pegasos CPU cards, that are currently being produced at DCE.

A Pegasos II with a G3 CPU will cost 299 Euro (that's about £220, note that all prices in this item exclude VAT) and the entry level G4 model will be 499 Euro (£360). Pegasos I users can buy a G4 CPU card for their existing system or trade in their existing board for a G4 based Pegasos II, both options cost 200 Euro (£145). Information on the speed of the G4 processors chosen will be available soon and Genesi are expecting the Pegasos II boards to be available in September.

The UK Pegasos distributor is at: <http://www.pegasos-uk.com>

For the latest news on MorphOS and Pegasos visit: <http://www.morphos-news.de>



GoldEd Morphed



In his MorphOS review on page 20 Sam Byford notes that the operating system is not currently supplied with a text editor. Fortunately it doesn't sound as if this state of affairs will last for long. Dietmar Eilert, the author of Gold Ed, is currently working on a native version of his editor for MorphOS. The product is to be known as MorphEd and it will be available free as part of the MorphOS software development kit (SDK). The editor is aimed at developers and will include a C programming environment for the GCC compiler. The full Gold Ed Studio will remain available as a commercial product for the Amiga and Pegasos.

For additional screenshots and further information go to the MorphEd web site: <http://morphed.dietmar-eilert.de/>

Bytes...

Amiga is the Favourite

MicroMart is the UK's only weekly computer trading magazine. In recent months the magazine has been carrying a regular Amiga page, AmigaMart, written by Sven Harvey. Amiga Mart covers happenings in the Amiga world and has small reviews of Amiga software - letting casual readers and ex-Amigans know that a comeback is planned.

In addition to AmigaMart the magazine has been running a competition to find reader's favourite home computer. Over three months enthusiasts for sixteen different home computers tried to persuade readers of the merits of their particular model. Despite classic computers such as the Commodore 64, Amstrad CPC and BBC Micro being in the running the Amiga and Spectrum emerged as the top two in the final vote. The Spectrum had a late rally but in the end the Amiga won through with 55 percent of the vote.

MicroMart is available from most UK news agents for the princely sum of £1.60. They also have a lively web site at: <http://www.micromart.co.uk>



Freeview

Henk Jonas has released his handy Metaview utility (reviewed in issue 9) as freeware. The program can be used to view, convert and catalogue vector graphic files in many formats such as IFF-DR2D, WMF, CGM and GEM. It is an ideal companion to DrawStudio or any other structured drawing package.

Download the full version from: <http://user.cs.tu-berlin.de/~jonash/>

Bytes...
OS 4 Blizzard?

Amiga OS 4 (take a look at our OS 4 Update feature on page 10 for the latest news) is currently being developed for classic Amigas with a CyberStorm PPC accelerator and, of course, AmigaOne PPC G3 and G4 systems. A version for Amigas with Blizzard PPC cards has always been anticipated, but never 100 percent confirmed; due to the complexity of supporting the range of A1200 systems and add-ons which have been released. As the release of OS 4 for the initial two platforms draws closer Hyperion need to make a decision about Blizzard PPC support. As a significant amount of effort will be needed to support A1200 systems they need to know the demand is there before they make the investment. Therefore if you have every intention of purchasing OS 4 for your Blizzard PPC based A1200 were it available then pledge your support in an EMail to:

timdq@hyperion-entertainment.com

Web Bytes...
Amiga history guide

The Amiga Interactive Guide, an invaluable web resource for anyone interested in Amiga history, has been renamed and redesigned. The site is now called the Amiga History Guide and looks extremely professional. On the site you can find such fascinating artefacts as interviews with Amiga developers, histories of Amiga companies, details of unreleased and prototype Amigas and even a list of Amiga magazines (which, of course, includes Total Amiga)!

The site was useful before but now it has a design to match the quality of its content:

<http://amiga.emugaming.com>

Audio Evolves

More information about the forthcoming release of Audio Evolution 4 exclusively for AmigaOS 4 has been made available, including the first screenshot and a list of features. AE4 is an audio recording and editing package with non-linear and non-destructive features as found in professional tools on other platforms. The program also boasts a wide variety of real-time effects which take full advantage of the powerful PPC processors supported by AmigaOS 4.

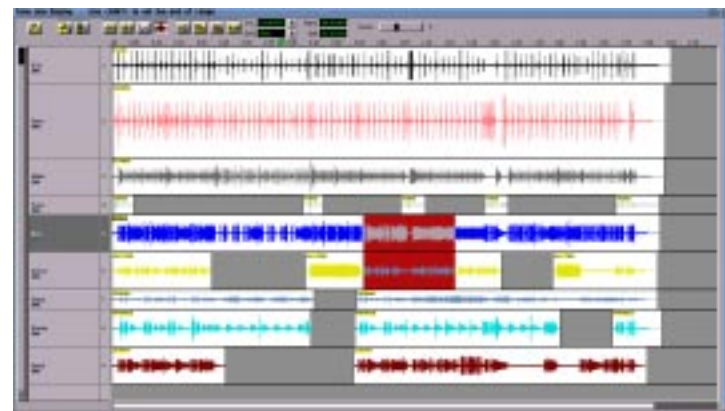

New features in version 4 include:

- Non-linear editing on the time line, including cut, copy, paste, move, split, trim and crossfade.
- Unlimited undo.
- Many grid options to align regions.
- Improved automated editing on

- the time line
- Metronome with freely adjustable time signature
- New plug-ins, including a new compressor, chorus, ducking delay and sound replacer
- Effect parameter automation
- ARexx interface
- Enhanced look using a 256 colour screen. Most imagery can be changed by the user.

Computer City in the Netherlands distributes audio Evolution 4 world-wide. The full package will cost 149 Euro (£110 approx.) and an upgrade from version 3 will be 70 Euro (£55).

For more details visit: <http://www.audio-evolution.com>

Spray on the Magic

Georges Halvadjan updates his excellent freeware paint program, Perfect Paint, so regularly that we can usually count on him to help us fill the news pages of Total Amiga. As we go to press, version 2.925 has just been released with many improvements and impressive new features.

Of particular note is the MagicSpray tool. This takes a collection of brushes and applies them to the canvas as you paint. As they are applied the program can randomly change the size, colour, contrast and brightness of the brushes, within user-defined boundaries. A set of MagicSpray brushes and settings can be saved as a project for later use or distribution. A selection of projects are included with Perfect Paint and more can be downloaded from the program's web site. MagicSpray is excellent for making backgrounds and is also great fun just to play with. A good example of MagicSpray is the coins project. This contains brushes of several different old coins; as you spray the coins

appear at random and in different sizes – you could use this to create an instant unique background for a presentation.

Some other features in the new version include:

- New "Adjust RGB level", "Auto RGB level" and "Chromatic correction" colour correction tools
- Improved text requester.
- Improved communication with

- TurboPrint.
- Brush preview in the "album" are shown with full transparency.
- Improved multi-step undo with history list window.

If you haven't tried Perfect Paint download this version now... it has many unique features and it's free! <http://gothic.fr.free.fr/>



A effect made in a few seconds with the Magic Spray tool.

Get a Load of This!

Pixel Art have released a new version of their visually striking graphical program launcher. Picload 4 is particularly noted for its beautiful look, reminiscent of the Mac OS X dock. The fact that Pixload looks so good is not a surprise, Pixel Art have been behind some of the most stunning Workbench backdrops and Amiga generated images of recent years. Apart from looking good Pixload has many handy features. Program and drawer icons can be added to the bar for

easy access, a clock can be displayed as can the status of the Miami Deluxe TCP/IP stack if you use it. Pixload can also display files of various types if you drag and drop them on to the bar. Interestingly Pixload is written in AREXX using rxMUI for its Interface.

Pixload is freeware and supports AmigaOS 3.x+ and MorphOS 1.3+. Download it from: <http://www.pixel-art.fr.st/>



Yet Another... YAM

Version 2.4 is the second major release of Yet Another Mailer since the original author, Marcel Beck, made YAM open source and development was handed over to the YAM Open Source team. There is also a version 2.4p1 upgrade that corrects some problems in the original 2.4 release.

In addition to squashing many bugs and generally improving existing features, version 2.4 has several new features including:

- Hierarchical folder list – folders can now be arranged into groups, and nested.
- Support for SMTP & POP3 TLS1/SSL3 using the AmiSSL.library.
- Email address cache – remember Email addresses used not in the address book.
- Recipient gadgets resolve aliases, real names and addresses on the fly.
- Automatically finds the suitable



- mailing list support settings
- Improved handling of mailto: links in mails.
- Write window search function.
- Status for individual folders in the app icon.
- Built-in mouse wheel support.
- Extended documentation.

Download the new version of YAM from: <http://www.yam.ch>

Frogger Plays Sorensen

Since mentioning it last issue FroggerNG has gone from strength to strength. In the latest version, 2.06, many bugs have been fixed making the program much more reliable. The synchronisation of video and audio has been much improved so it stays correct during normal play and after seeking to a new point in the movie. The most interesting addition has to be support for the Sorensen 3 video codec (thanks to an anonymous

programmer on the open-source ffmpeg team). Sorensen 3 is often used to encode commercially produced Quicktime (.mov) movies such as film trailers – it produces excellent looking video at reasonable file sizes. In our screen-shot you can see the recent Apple advertisement playing in the 68K version of FroggerNG running on Amithlon. FroggerNG is shareware, costs 15USD (about £10), and can be

USB Updates

Poseidon

Chris Hodges has released version 2.2 of his popular USB driver package, Poseidon. As well as fixing a bug in the Subway driver and improving compatibility with mass storage devices, the new version includes two command line tools to drive previously unsupported USB devices. DRadioTool can control inexpensive USB radios from D-Link and GemTek; these devices are controlled by the computer and output their sound from a traditional jack rather than by sending it across the USB bus. UproarTool can be used to upload songs to the Valencia MPX portable mp3 player and others based on the same chipset.

Download the latest version from: <http://www.platon42.de/>

Thylacine

A new version of the USB stack supplied with the Thylacine USB card (reviewed in issue 13) has been released. This version adds support for the Human Interface Device (HID) class, the most obvious benefit of this is the ability to use wheel mice. Thylacine owners will be pleased to see this stack developing and we understand that it will also be used as the default USB stack for AmigaOS 4.

The update can be downloaded from: <http://thylacine.boing.net>



registered on-line via Reg.net. To download a demo version and to view a list of the audio and video codecs supported go to the Frogger web site: <http://frogger.rules.pl>

Web Bytes...

[amigaworld.net](http://www.amigaworld.net)
amiga community portal

An excellent new portal web site is causing quite a stir in the Amiga on-line world. AmigaWorld.net has the usual news reports and forums for discussion but also has several unique services. First up the site has a rather stronger moderation policy than some other Amiga forums, this helps keep petty bickering down (whether you appreciate this is probably a matter of taste). Fleecy Moss, Amiga Inc.'s chief technology officer, regularly answers ten questions posted by Amiga World members. Initially this was a weekly event but with over 100 questions answered it changed to bi-weekly recently. New screen-shots of AmigaOS 4 from Hyperion have been posted at the site too. Amiga World also has a companion IRC channel and a streaming radio station playing classic Amiga tunes.

All in all it's an engaging site worth adding to your hot-list: <http://www.amigaworld.net>

[MorphZone](http://www.morphzone.org)

If our review of MorphOS this issue (it's on page 20) perks your interest you might be looking for more information. In that case MorphZone is a good place to start learning about the operating system and Pegasos hardware. The site features news, forums in several languages and a database of links to other sites with further information. Another good feature is the Ambience gallery. This is a selection of user provided screenshots which show off the MorphOS Ambient desktop environment (hence Ambience) and skinable GUI. <http://www.morphzone.org>

Fleecy Speaks

Amiga Inc's CTO briefs us on the progress of OS 4.0 and looks forward to its first public showings.

By the time you read these words, the first public showings of AmigaOS4.0 running exclusively on a PPC processor should be well under way. An event that the community has been waiting for since 1996, that has started and stopped on numerous occasions, that has been derided and refused by those with their own hidden agendas, that has been delayed by mistakes and resourcing constraints will have happened.

The importance of this cannot be over estimated. Finally, in the public arena, all those claiming that AmigaOS4.0 is a fabrication, a lie, a ruse will either have to slink back into the shadows or else change their tune, from 'it will never happen' to 'it isn't any good'. Whatever new tune will leap from their lips, this public showing marks a turning point in the nightmare and misery since Commodore went bankrupt. The question is not now 'Will it ever happen?' but 'When will it happen?'

This change is significant because the certainty of a future for our platform will mean that users can commit to continuing to support the Amiga, developers can see a real and advancing product and get hold of the necessary tools and documentation to create new product for it, and dealers can begin to develop their own strategies for carrying and promoting the platform within their geographical locations. All of this means more talk, and more importantly more positive talk, about the AmigaOS, and this will spread throughout the great communicator that is the Internet. More communication means more users and that means we are back on our way up again.

The excitement in the AmigaOS4.0 development group has been palpable. As with any project, we have had to work long and hard across the desert where most of the work takes place with seemingly little real benefit. In this quiet time, there has been little to talk about, and thus

little public information to release. Mischief makers have used this silence to their own ends but ironically the spreading of rumours and the attempt to develop a malign climate in the community has done nothing but spur the team to greater efforts.

Now though the desert is behind us. It started with the announcement that we had been able to boot into Workbench on the PPC processor of a CSPPC board. Yes, the only PPC binaries were ExecSG, the 68K emulator and parts of the Hardware Abstraction Layer, but the rest of the AmigaOS, in 68K binary was running through the 68k emulator AND IT WAS WORKING!!!

From that point progress has occurred on an almost daily basis. The completion of a GCC compiler. The conversion of almost all 68k assembler to portable C. The porting of all 68K C source so that it could compile using the GCC compiler (the importance of this being that it requires a simple

switch to change the compiler from a 68k target processor to a PPC target processor).

As I write this, we have just had our first E-Mail sent out from YAM running MUI on a Picasso96 screen through the new Roadshow TCP/IP stack over an ADSL modem. Each one of those systems on its own still in 68K but running via the emulator on the PPC processor. Given what is required to run within the AmigaOS to allow each of those systems to run, you can see how close the project is to completion.

Our first set of benchmarks shows that even with the interpretive emulator we are using (it provides more compatibility but with the trade-off being a slower speed), we are getting 68060 speed and responsiveness, and that is running on a 200 MHz PPC processor. With more of the AmigaOS running as PPC native binaries and with the slowest AmigaOne computer debuting at 600 Mhz, we are confident of having a product

that can more than hold its own with the industry leaders in terms of performance.

The first public showing of AmigaOS4.0 is part of a rolling European roadshow organised by about a dozen dealers (the number keeps growing all the time) and at each successive show there will be more and more of AmigaOS4.0 shown. This is part of a strategy that will slowly push AmigaOS4.0 into the public eye, all with the eventual aim of a combined public release and launch show. We will still not announce an actual release date because we have committed to not doing that until the final, shippable product is in front of us, but I hope you can see from this text and from the reports of the shows that will have happened that we, through the dedication of a passionate community of users, developers and owners are very close to what we have all longed for over the past eight years, the rebirth of our platform.

AmigaOne Update

Fresh from the IBM technology forum, Alan Redhouse (MD of Eyeteck) reveals the specs of the AmigaOne Lite.

As I sit in a Boston hotel lobby - it was the 2003 IBM technology forum this week - frantically pecking out this update in a desperate attempt to meet Robert's deadline, I've just worked out that the AmigaOne has now the highest sales of any available ATX form factor PPC board in the World. That is not so much a measure of major sales success, but rather underlines just what a new product family the AmigaOne is, and how pioneering even the Linux port to the new hardware has been. Debian Linux is now the officially supported distribution on the AmigaOne Earlybird boards and systems and the success of this distribution is entirely down to those early adopters on the A1G3dev list. In this respect I must give special thanks to Ross Vumbaca who did a superb job on the Debian PPC installer for the AmigaOne. The AmigaOne is now regularly used by owners for browsing and email, productivity applications, TV/video capture, media playback and as a web server in its own right. The installer disk also makes it easy to set up and use UAE, and installs Workbench 3.1 and the Magic Pack software.

In terms of board types sold, the majority of 'Earlybird' purchasers have opted for the AmigaOne-XE G4 board/systems, although the demand for the G3 systems with the option of a subsequent upgrade to a single/double G4 CPU has also been higher than we originally expected. Many users of the G3 systems have overclocked these to 933MHz (thus voiding their warranties, but apparently without any adverse effects being experienced). On the other hand the current G4's that we are shipping are using 933MHz 7455 CPU's clocked down to 800MHz (to meet the advertised specifications) - surely making this, the selling of an underclocked CPU, unique in the Amiga marketplace!

As you have probably read elsewhere, OS4 has been widely

shown throughout Europe running PPC-native on an A4000 CyberstormPPC accelerator. Hyperion are now hard at work completing the porting to the AmigaOne hardware. We are still holding the 'Earlybird' offer (ie an AmigaOne supplied now with Debian Linux/UAE and a free copy of OS4 when available) open until the official launch date of OS4 for the AmigaOne is announced. This gives you the opportunity to start using the power of your AmigaOne under Linux/UAE now and hit the ground running when OS4 is released.



One of the many MicroITX cases that will suit the AmigaOne Lite.

AmigaOne Lite

In the last edition of Total Amiga I gave a brief overview of the AmigaOne Lite - an entry level AmigaOne designed to both as a CD32/A1200 successor and for use in embedded systems such as kiosks, STB's etc. However the more observant of you will have realised that in the last issue I actually described the AmigaOne-SE Lite - so why the change of name?

In the interim period we have re-examined the costs and decided that it is economically feasible to significantly increase the A1-Lite's specification and flexibility within the same overall target pricing. As one of these changes is to use the standard A1XE CPU modules (plus a new entry-level 750CXe module) we dropped the 'SE' from its name.

The full specifications for the AmigaOne Lite are as follows:

- Micro ITX form factor (170mmx170mm)
- Gigabit and 10/100 ethernet on board

- 133MHz UDMA RAID IDE controller
- USB 2.0 on board
- IEEE 1394 ('FireWire') on board
- 2x AGP graphics on board with PAL/NTSC TV out
- AC97 sound on board
- 1 x PCI133MHz slot (horizontal, via supplied riser card)
- Cardbus slot for flash card support (diskless booting, applications, games slot etc)
- Usual legacy PS/2, serial, parallel ports

Being a standard form factor it will fit in a standard micro ITX case, such as the one shown in photograph. Please visit www.morex.com.tw/minicase.htm and www.mini-itx.com to see other suitable case designs.

We are aiming to bring the AmigaOne Lite to market early next year.

Well that's all this issue - must dash - I've got a plane to catch!

Buzz Word...

It's been an eventful couple of months for the world's favourite niche computer platform, and of course your ever-snooping agent has been there to dig out the information.

Amiga's New CEO

Buzz Word has heard that Amiga are about to get a new CEO but it won't be Garry Hare; apparently the whole Genesi / Garry Hare story was a setup designed to produce confusion. The new CEO is a man who will bring many millions of investment dollars back into the company. The Man's name? Jim Collas. Yes, that's right, the former CEO when Amiga was owned by Gateway is the man who will bring home the bacon for Amiga Inc.

Rumour has it that Jim Collas is very keen to turn Amiga back into a hardware company as well as a software company. Collas has a high reputation in computer circles and is apparently looking forward to finishing, and I quote, "what he started". Apparently Bill McEwen and Jim Collas are very good buddies and in regular contact, so this comeback is no surprise. Bill McEwen will remain at Amiga as president.

Amiga's competitors and detractors should beware, Collas is ruthless and will not tolerate petty tittle tattle. Expect Lawsuits of various types to be flying from Amiga any day soon.

Eyeteck "Woes"

Yup Eyeteck are in trouble, apparently. It seems to stem from the fact that they underestimated the high demand for AmigaOnes. Demand has surged dramatically since the first AOS4 screenshots hit the web and Eyeteck are now having to consider ways to meet the increase in demand. Just wait until OS4 finally ships - they are going to be under siege! Still I'm sure Eyeteck and Amiga retailers selling AmigaOnes are smiling very broadly at this happy problem.

Pirates Ahoy!

The revival of Amiga as a platform seems to be gathering

momentum, many ex-Amiga users are returning to the fold asking questions, getting their Amigas out of the cupboard, loft or basement etc., and dusting them off for one more go. Unfortunately some of those ex-users are asking for keyfiles to programs such as amIRC, MUI and IBrowse plus of course asking where they may obtain free downloads of OS3.1, 3.5 and 3.9. These Morons are obviously not aware of the fact (or don't care) that piracy played a major part in the downfall of the Amiga last time around. Sites like www.back2roots.org are a rare exception on the Internet, they seek permission from the author/copyright holder before adding the titles to their site. However the majority of sites

out there offering commercial Amiga software for download do not - they are pirates.

Amiga have made it quite clear they are not willing to tolerate any form of theft of their Intellectual Property, such as Amiga ROMs and AmigaOS.

Buzz Word urges all his readers not to give in to piracy, report any websites found containing illegal files to gary@amiga.com and discourage any potential pirate asking for keyfiles, ROMs and OSs. The Amiga market is poised for a second chance, don't let the Pirates ruin it.

AmigaOS 4

Pre-release publicity for Amiga OS 4 has started - Total Amiga sent John Chandler to search for the facts behind the hype.

The build up to the release of AmigaOS 4 continues. I'm wary of saying that it's really close now because I've said it before and been wrong, but the signs are very good - this time I believe I'm going to be right. OS 4 is itself ready and running, with the outstanding work now involving the migration of some remaining components to native PowerPC code.

The development team have released more information into the public domain, and you might also have spotted AmigaOS 4 adverts running on websites and in this very magazine (page 9) as well as a demonstration tour of the beta-test version (see below) which will be spreading the word around parts of Europe as you read this. Subscribers to Amiga's club magazine will have also been treated to further updates and more in-depth information on aspects of the OS. In addition, Hyperion have started to try and gauge the interest for a BlizzardPPC version of OS4 - something that wouldn't be



An updated Kickstart for OS 4 can be stored in the flash ROM on several new Zorro cards including E3B's ALGOR USB.

worth bringing into the public forum until they were absolutely sure the final stages of the current project were in place.

Significantly, during April, the new DOS and AmigaInput components were amongst the latest modules to enter the final beta-testing process, DOS V50 having finally cast off all the BCPL legacy of old. Cyberstorm users will also be pleased to hear that drivers for the on-board SCSI controller and the Permedia 2 graphics chipset are also due to enter the final stage, as is the Radeon driver for Picasso 96.

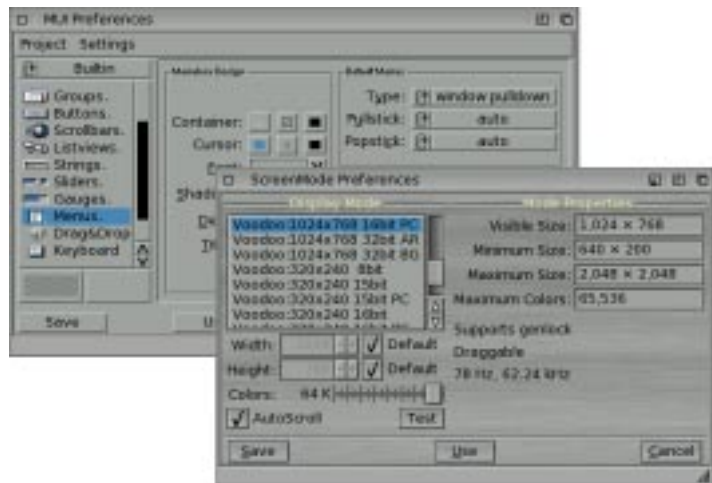

MUI 3.9 is included with Amiga OS 4 for compatibility with legacy applications. The default settings are designed so MUI applications fit in with programs using Reaction, the standard OS 4 GUI tool kit.

Emulation

The 68k emulation, which provides the all-important bridge between old and new, has also been progressing well. Integration has now reached the stage where OS 3.9 successfully boots on PowerPC hardware under emulation, and OS 4.0 itself can boot into Workbench and run applications.

This stage of development highlights the fact that the emulation and integration has reached a significant level of maturity - a stage which many naysayers proclaimed to be either fraught with problems or downright impossible. Even on a system running a native ExecSG (the OS4 kernel) with a base OS consisting of 68k modules, an extreme worst case scenario if you like, the performance on a Cyberstorm card has been tested as comparable to a 68060 - and that's standard emulation without the Petunia JIT (Just In Time) support. Of course, with the 68k modules handled by JIT emulation you gain an immediate and dramatic performance boost - and when the modules are native PowerPC... well, you can guess that one for yourself.

Migration

With the OS 4.0 code successfully running, work has now shifted towards the final migration of the software to native PowerPC. This might sound like a large amount of work, but in fact the whole development roadmap has been geared towards this very moment, with code now in a stage to be seamlessly recompiled and tested as native PowerPC modules. With the source building under GCC and tested rigorously on a stable foundation, the migration path is proving to be swift and painless.

Part of the migration process, not to mention the legacy application support, also relies on the ability to easily swap 68k libraries with PowerPC ones - without the need for trickery or re-writing on the part of the application developers. This has already been successfully implemented and ensures that the change-over between 68k and PowerPC, not just for the OS itself, will be a smooth one.

Kickstart 4.0?

While Kickstart was starting to look like an obsolete concept, remember that OS 4 doesn't require it like previous versions of the OS, the concept of ROM-based functionality is one that isn't going to go away. Devices such as STBs or multimedia kiosks, to list just two examples, could require such a capability and a variety of third parties have approached Hyperion regarding the creation of a Flash ROM for OS 4.0. Jen Schoenfeld's company, Individual Computers, and Hyperion began such a project back in 2002, culminating in

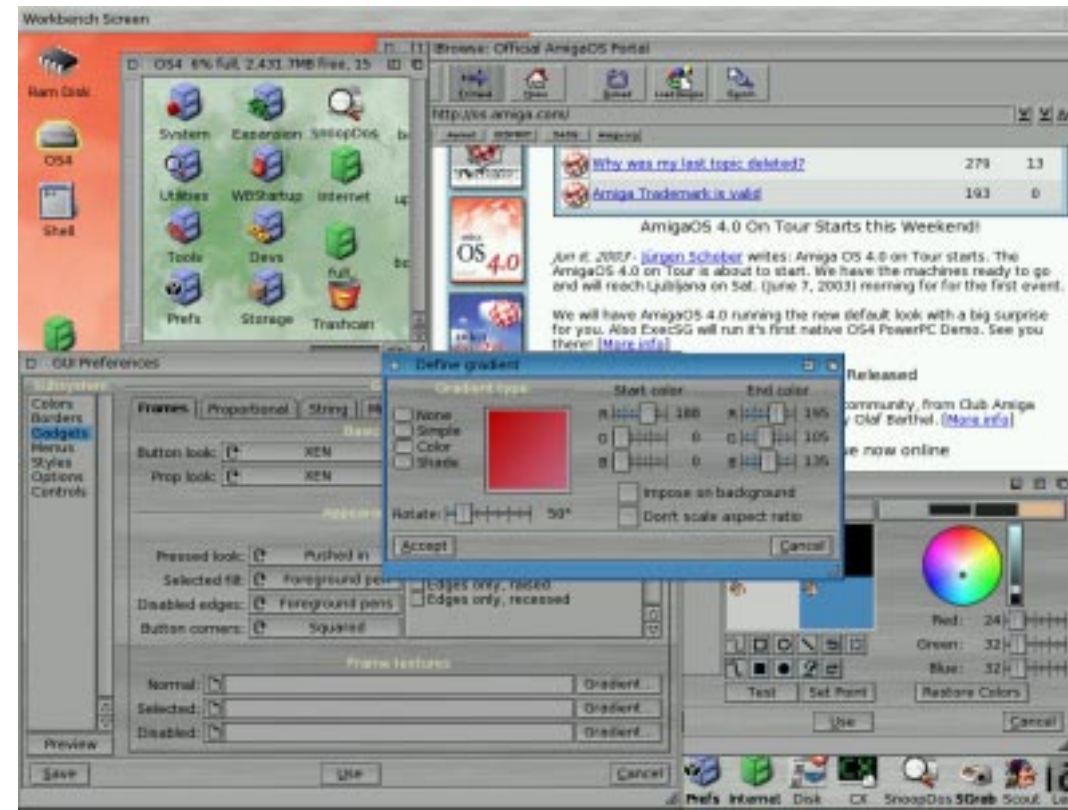

the "Kickflash OS4" Zorro card, and Hyperion have also begun to work in partnership with E3B to officially support their ALGOR and ROMulus Flash ROMs for 'classic' Amigas.

CDs and DVDs

Ben Hermans has described the CD and DVD support as "by far the most complete" of its kind for the Amiga. As well as the previously announced support for all the common CD formats (RockRidge, Joliet, HFS) the system will cover UDF and UDF-Bridge format DVDs. The only missing piece from the package is any kind of bundled software for playing DVD movies, due to the high licence fees for CSS. In his recent Amiga.org interview, Ben highlighted the work of the open source community in providing the necessary decoding technology as a third-party option.

Documentation

Not much has been said recently about the documentation for OS 4. Work is under way to ensure OS 4 is released with the all-important user documentation, including extensive work from a team of translators (rumour has it the

Klingon tongue could be added after all the usual Earth languages - anticipating a universal userbase perhaps?). Unfortunately, Olaf Barthel's updated ROM Kernel Manuals

"not even the hardest doom-monger can deny AmigaOS 4 is looming large."

for developers will not be ready in time for the launch, but this is hardly unexpected given the nature and scale of the task.

Pegasos Support?

Hyperion and Amiga made it clear that they would be happy to see OS4 on other hardware provided the appropriate licensing measures and support agreements have been met. It's no surprise, therefore, to hear that the possibility of a Pegasos version in the future is still an open avenue for exploration. Ultimately, the decision is for Genesi to agree to the licensing and provide all the technical details required to complete a port fully and accurately. Of course, there is also the issue of whether such a port makes financial sense to all parties, including Genesi, given the current number of Pegasos systems available until the Pegasos II hits the streets later this year.

OS4 On Tour 2003

As the release rolls nearer, point.design have taken the opportunity to show AmigaOS 4, as it currently stands, to

groups of people across Europe. At the time of writing, this tour hasn't made it as far as the UK but the result is an excellent way to give people a chance to see OS 4 up close before the official release. The demonstration will feature the new version of AmigaOS with a native PowerPC kernel running on a Cyberstorm PPC. In addition, a variety of modules will be included in the



OS 4 includes anti-aliasing to make fonts look smooth and unpixelated. This is particularly effective on higher resolution displays.

One of the recently released screenshots giving us a feel for the OS 4 default look (which is currently around 80% complete). Notice the powerful GUI preference program with userdefineable gradients in the foreground.

presentation such as the Roadshow TCP/IP stack, the CD/DVD support and the new AmigaInput.

AmigaOne hardware will also be available to view, though not running OS 4 as yet, along with a few surprises - for example, the anti-aliased font support made its debut on the tour, while the Augsburg Computer Forum event will feature the premier of the C-One (a fantastic C64 clone) and E3B's Algor USB controller, mentioned earlier in connection with future OS 4 ROM support.

If you're lucky enough to be near one of the tour dates, it goes without saying that you'd be well-advised to take the opportunity and check out the real deal. Details can be found at: <http://www.oase.at/amigaos4ontour.html>

(But if you can't make it, you can always take a look at the official OS4 screen-shots accompanying this article and also available from <http://os.amiga.com/>)

To Sum Up

There we have it. Without wishing to put a jinx on things, the final stages of the project are very much upon us. OS 4 as a complete system is ready, with the emphasis now on completing the migration of modules to PowerPC as well as the final finishing touches to an impressive package. How long until we see a public release for Cyberstorm PPC and AmigaOne remains to be seen, but not even the hardest doom-monger can deny AmigaOS 4 is looming large.

Selling the New Amiga

Finally it's back - but is there room left any more? Andrew Korn discusses AmigaOS4's chances in today's computer market.



All the frustration and decay in the Amiga market over the past decade can be summarised by one simple fact: there has been no new generation of Amiga in all that time. Amiga OS3.5 and 3.9 were largely cosmetic upgrades, a setpatch for community morale if you like. With AmigaOS 4.0 imminent, is the long hard winter finally coming to an end? If only it were that simple.

This is not about the technical merits or flaws of AmigaOS 4. It suffices to observe that with this new generation, Amiga OS and hardware have improved to a sufficient degree to compete, while retaining the many unique advantages we all admire so much. The remaining price/performance and applications gap will provide Amiga less of an obstacle to future success than the problems of rediscovering a place in the market.

Vanished Market

Current enthusiasts and interested ex-Amigans can provide a useful starting base for Amiga, but this isn't the mid 90's any more and the remnant community is now too small to

"People already know about Amiga, even if they don't know that it's back."

provide sufficient market impetus - we really need to take a look at the Amiga OS as a brand new product. Amiga OS has a long history, but in terms of market penetration, distribution channels, industry and consumer mindshare, sector placement, and all the rest of the overwrought terminology used to describe the key factors in market success, AmigaOS 4.0 might as well be 1.0.

Of course the Amiga has one distinct advantage - awareness. In the case of a real new product launch, awareness is an essential

asset, the first target of any marketing spend. People already know about Amiga, even if they don't know that it's back. This is not as useful as the kind of multi-million dollar marketing campaigns a Sony or Microsoft can afford, but it's

the next best thing - and an awful lot cheaper.

We shouldn't fool ourselves into thinking the name alone gets a free ride, but the Amiga legacy is a foot in the door. There are, for example, few games houses in the UK who do not remember the Amiga's prime as a golden age of games development. If Amiga tries to evangelise the new platform to these developers they'll get an attentive and even eager audience. However the bottom line is what really counts, and a decision to go ahead would be predicated on one simple calculation - is there enough of a market?

This is of course the catch-22 of any new platform. A platform needs software to sell, and needs to sell before software publishers are willing to invest in development. If you're Sony or Microsoft you solve this problem by spending further millions buying leading software developers and reassuring publishers with promises of massive marketing budgets. Amiga can't do this; they simply don't have the vast cash reserves required.

A Change of Focus

Luckily the computing market has been becoming a more

complex place in the past few years. With some clever positioning Amiga can sidestep the catch-22. We just have to look beyond the scope of the AmigaOne. Removing the hardware dependencies from AmigaOS was not just about finally getting it to run on PowerPC, it was also about opening doors. The AmigaOne hardware platform is simply not going to change the face of the Amiga market - it's a niche product that doesn't really provide a hardware advantage over x86 products for the average desktop user. Sure there's a power consumption advantage, but that's really only an issue to people running racks of servers which will probably be running Linux anyway. On the other hand it's now going to be a lot easier to develop versions of the Amiga operating system for other, non-desktop devices.

We're all well aware of the benefits that AmigaOS' size and efficiency can bring us as desktop users, but this offers considerable potential for extending the Amiga family beyond the desktop. As a complete desktop-capable multi media OS that is compact and efficient enough to run on low end hardware and was originally designed for low resolution displays, AmigaOS would not require major re-engineering to work on smart phones and PDAs. This is a market where analysts have predicted sales as high as 200 million units next year, and unlike the desktop market Microsoft don't already own it.

Previous attempts on the STB market have not been productive, but the STB market has matured, with worldwide sales in the tens of millions annually and growing fast. So far smaller, far less functional embedded solutions have suited the STB market, but with the growing interest in the "livingroom PC" concept, there is surely a market for an STB with full Internet access, media storage, good playback facilities and a useful range of basic but functional apps. The Amiga originally found more space in people's living rooms than on desks, and perhaps

Need Somebody?

The Amiga technology is more than capable for the task. All Amiga really need to secure for a triumphal comeback is high volume distribution channels - simply put, a way of getting the Amiga platform out into the market in healthy numbers. This almost certainly means linking up with other companies with the weight to push a hardware platform. The deal Amiga had with Nokia for their Media Terminal was an good example of how this could work, although equally it demonstrates the inherent

"Whoever has the product that delivers that next paradigm shift will have the opportunity to break Microsoft's dominance."

the STB market is finally ready to take it back there. One great advantage for Amiga of seeking this market sector is that it would bypass that application catch-22. A platform of this type requires well-designed apps to cover its core functionality, easily done in house - the only killer app here is a well designed interface.

vagaries of this market. We can hope that it at least indicates an interest on Nokia's behalf to work with Amiga on future projects, although there are many other possibilities such as Ericsson, Motorola, Pace, Philips, Seimens, Samsung etc. Of course as the home media terminal concept spreads, other companies will appear on the scene. Sony



Amiga OS in the palm of your hand?

have made their first move with the announcement of the "PSX", a Playstation 2 with hard drive, networking, PVR and DVD record/playback facilities.

Eyetech's relationship with Taiwan-based Mai Logic has opened one very interesting door - China. Missile tests and idle threats of invasion notwithstanding, China and Taiwan share a considerable dose of language, culture and history, and the Chinese are eager to leverage this to take advantage of Taiwan's IT design and manufacturing expertise. Eyetech's Alan Redhouse has had the opportunity to demonstrate the Amiga OS to major Chinese IT concerns, and he believes they are impressed by what they have seen. The Chinese have an IT gap that they badly need to bridge, and a low cost super STB could well be the ideal solution for them. Selling AmigaOS as the de facto standard for computing in China would be a vast coup.

disappointment that common wisdom has dismissed the Amiga's chances in the desktop market. The paths outlined above could of course provide a market for software development that would give a major boost to the niche desktop Amiga platform, but is that really the most we can hope for?

Microsoft gained their dominance in the home by being in the right place at the right time. They will, I believe, retain that dominance until there is ground-breaking shift in the way people use computers. Whoever has the product that delivers that next paradigm shift will have the opportunity to break Microsoft's dominance. Amiga has been pursuing some fascinating blue-skies technologies which are not due to be delivered into Amiga OS in the very near future, but have the potential to truly change the way we use computers. Of course Amiga aren't the only people to be interested in developing Operating Systems beyond the Xerox / Apple Lisa inspired model, but the whole point of the future is that it is uncertain, and with uncertainty comes opportunity - but that's a subject for another article.

The Impossible Future?

I'm sure you'll all agree that the possibilities outlined here are exciting; Amiga OS could just have an important future in the computing markets of the world. I'm equally sure that you'll also feel a sense of

Popular Comeback Myths

1. *The Amiga name has been so mired with vapor and arguments that it has lost all value.*

FALSE. Outside the community nobody pays attention to the details. They'll take a look when we've got something to show, but the squabbling is instantly forgettable.

2. *Amiga don't care about AmigaOS, only Amiga DE.*

FALSE. Amiga OS is necessary to the plans for DE.

3. *Games developers loved the Amiga and will quickly return to the platform.*

FALSE. Many would no doubt find the notion of returning to the Amiga appealing, but it is expected sales figures that determine what platforms a game is developed for, not which platforms the developer likes.

3. *The split between AmigaOS4.0 and Morphos will be fatal - there is only room for one OS in this market.*

FALSE. To be honest it's too small for just one Operating System as well. New markets will have to be found, and there's plenty of room out there.

5. *Amiga need a "killer app." to succeed.*

SEMI FALSE. Killer app. Software wins you market niches. Most people use necessary apps, not killer apps. However killer apps don't necessarily mean application software - Microsoft's only killer app is ubiquity.

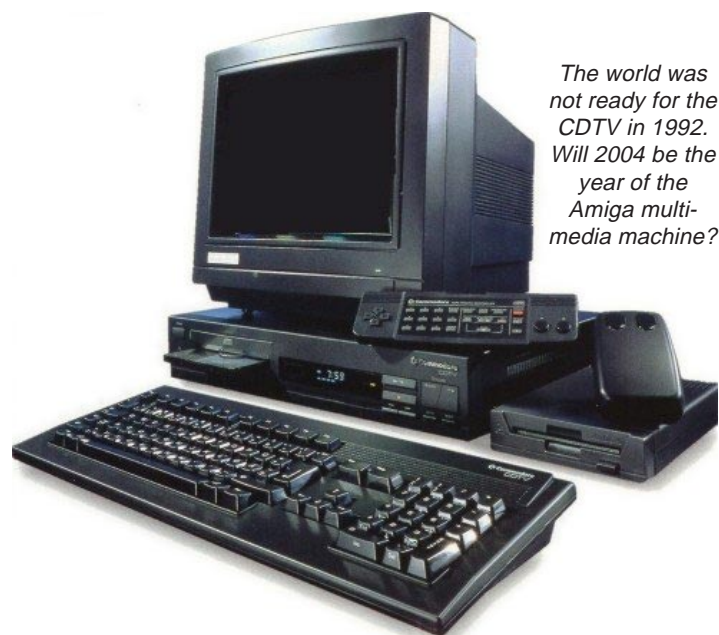

The world was not ready for the CDTV in 1992. Will 2004 be the year of the Amiga multi-media machine?

"It's not about the desktop!"

With Microsoft entrenched on the desktop Amiga must look to other markets to succeed. John Chandler wonders what lessons we can learn from Apple's recent successes.

You'd have to be pretty naive to think that Amiga has a chance of defeating the might of Windows on the desktop. Sure we all believe that AmigaOS has what it takes, but sadly the real world doesn't work that way. Besides, Windows has been under pressure from many rivals over the years and those who have tried to seize control with a head-to-head clash have failed – BeOS was going fine until it tried, MacOS has resigned itself to second place, even Linux hasn't really made it to the average desktop despite massive improvements and support.

But that's okay, because the desktop market has almost reached stagnation point – there's little room for expansion and innovation, it's no longer the big thing any more. To

divert resources in the hope of reaching top of the desktop pile is a waste, and those developing non-Windows operating systems are starting to realise that.

Now I must make a confession. I've started to dip my toes in the world of MacOS X. Well, actually, I've probably gone past the toes stage and I'm wading towards the deep end. No, I've not abandoned the Amiga, the A4000 is still my main machine, soon to be replaced by an AmigaOne G4

"The problem is, the Apple dream is limited to the Apple universe."

XE. I needed a new laptop earlier this year and my choice of a non-Windows platform with a low profile and good battery life took me towards the new Powerbook G4 12". MacOS X on this beast flies – nothing since the Amiga has made me feel more at home.

Apple made an interesting choice with OS X. Let's face it, the old MacOS was pretty naff considering - a friendly, consistent UI for sure, but it was crash-prone, multitasked poorly and was effectively a sealed box that the power user couldn't easily poke around with. Us Amiga users were lucky in that respect, we had a platform that was pretty slick and accessible on so many levels – from console-like game playing right up to full blown power user geek box. MacOS X introduced that to the Mac, bringing all the friendly consistence of the MacOS on an impressive BSD UNIX core for the geek appeal.

But all this wasn't a vain attempt at bolstering the artillery in the desktop war, it was another stage at switching the direction – building a solid foundation for the future. Take the Apple designs for hardware – the iMac

changed the marketing of a computer, bringing it into the role of home appliance. What would you prefer sitting in your home: a dull, beige box or some funky, colourful piece of tech-sculpture? Okay, so it looked like a plastic goldfish bowl, but it shifted units – people thought different, just as Apple said they should. Nowadays, the really hip computer companies wouldn't be seen dead launching a beige box.

Likewise, people started using

MP3s so the electronics companies started to mass produce MP3 players, meaning people could take their music and play it away from their computer. Apple's iPod does just that, but works seamlessly with their Apple Mac desktops and laptops. I plug my iPod into the Powerbook and it automatically synchronises my music, swapping all kinds of metadata such as when I last played a song or what rating I gave it. There's nothing particularly special about this, but it's such a smooth and trouble-free process, the iPod is a mobile extension of my Powerbook, my lifestyle.

So what? Well, Apple are now picking up on the content game and this is where the iPod slots in so seamlessly. You know, the content that Amiga have been talking about? Apple have realised that they're no longer in the business of selling hardware and software, they're shifting technology that enables you, your friends, your family, your colleagues to access digital content. The launch of their on-line music store, supplementing the whole iTunes/iPod experience, has been an overwhelming success, shifting paid-for music far beyond most people's expectations. They hit the sweet spot and tapped into



Apple's iTunes integrates with both the iPod and their on-line music store.

what people really wanted. It's just the start and I predict Apple are going to follow that whole avenue far beyond downloadable music. In fact, you can already obtain spoken word audio (books, journals, newspapers) and even textual content for your iPod.

But here's the crunch. Apple might have sussed the trend, but they've not realised the whole potential, in my humble opinion of course. The problem is, the Apple dream is limited to the Apple universe. Okay, Windows iPod users are catered for to an extent, but the truly seamless path is that based around the Macintosh user, running the MacOS X operating system on their Apple-branded designer home

appliances hooked up to their matching iPod. Even all the applications software is increasingly developed by Apple themselves.

The Amiga path is broader than that thanks to the Amiga DE. The underlying OS and hardware becomes an abstract entity, with DE layers eventually existing on Windows, AmigaOS, Linux and heck, maybe even Mac OS X. ARM, PowerPC, x86. Scaling from phones and PDAs right up to your laptop or home server, blurring the boundaries between each class of device. Significantly, this content isn't static like MP3s, it can be dynamic - games, applications, multimedia presentations, intelligent agents.

More importantly, Amiga have acknowledged that they can't, indeed shouldn't, do everything – they're laying out the tools, the technologies and the infrastructure to help others find ways to create, distribute and enjoy the content. From bedroom coders right up to large software and hardware companies, musicians, writers and artists, there's a diverse ecosystem in the making - one which should evolve into something more long-term, more sustaining, more pervasive and multi-platform.

The Game Packs so beloved of Microsoft and all those PDA and mobile phone companies are just the tip of the iceberg - a potentially huge and diverse market has been exposed, unlocked by the enabling technology and ideas of companies like Amiga. This is the real arena for innovation and expansion. The desktop will survive but it will no longer be the centre of attention – the future lies in the unexplored universe surrounding it.

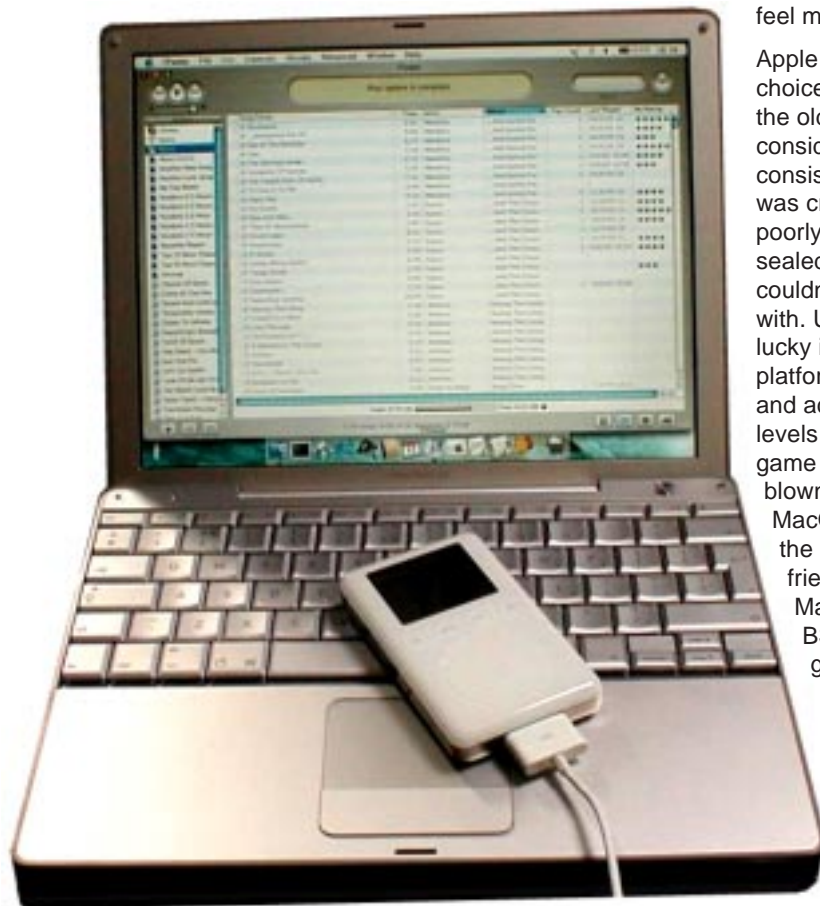

Apple's iPod is more than a cool mp3 player, it is an extension of the desktop (or laptop in this case) computer.

Review Scoring

Total Amiga's review scoring policy has five simple ratings rather than a percentage or out of ten system. Because the usefulness of a product very much depends on you, the user, we would far rather you read the review and used the information provided to see if it satisfies your needs. In our reviews we try to include enough detail so you can decide if a product is for you.

You might logically now ask "Why have a rating system at all then?". We think it is still useful to have an overview of the product; for example often it is necessary to explain a product's shortcomings. In a review, with limited space, these can seem to overwhelm the good points. The rating allows authors to say that they still think it's a good product despite its flaws.

Top Notch!

This is an excellent product which we feel is nearly perfect. A must have product if you're interested in the genre.

Pretty Good

A good product that works well but has room improvement. Definitely worth buying.

Okay

A product that works but has areas that could be improved. Could be worth purchasing if you can accept the limitations.

Could do Better

A product with major flaws that has potential to be improved. Only worth purchasing in this state if it's your only option.

Forget It!

What can we say – steer clear, this is a product that should never have been released.

www.amigaworld.net
amiga community portal

Amiga World is a Website and IRC Chatroom dedicated to delivering the latest news and a place for discussion

Includes Regular Q&As with Fleecy Moss, Internet Radio, Downloads, Buy & Sell Classifieds, Forums and Links Directory

Amiga World Staff will carefully monitor the comments posted on the website so that any undesirable elements attempting to start a flame war or cause an offence are firmly dealt with. This will ensure that ordinary decent users and developers can feel free to participate without having to worry about being insulted by undesirables.

www.amigaworld.net **chat.amigaworld.net**
amiga community portal the friendly chatroom

AROS: The DIY Amiga OS

Richard Drummond introduces us to a project that, until recently, has largely been of interest to developers.

Could it now have an impact on the wider Amiga community?

For years Amiga users have been stuck with two problems: a lack of new Amiga hardware and no real development of AmigaOS. The dwindling Amiga community has steadfastly waited for some solution to these problems, and, at last, the wait seems nearly over. Ignoring any politics involved, two similar – albeit competing – modern Amiga platforms are now near release, the AmigaONE with AmigaOS 4.0 and the Pegasos with MorphOS. Both are PowerPC-based computers driven by a PowerPC-based re-implementation of AmigaOS. But, did you know that there is a third and very different way to run an Amiga-like operating system on fast, new hardware? That third way is AROS.

AROS, the Amiga Research Operating System, is an open-source project whose aim is to create a portable operating system that looks like, feels like

and is compatible with AmigaOS 3.1. The project was initiated by Aaron Digulla in the dark days of the mid 90s, when the prospects for any official development of AmigaOS looked bleak. Commodore had gone down the pan, and Escom would not be long to follow. The thinking behind AROS went something like this. If the Amiga community

"The open nature of AROS means that it could be the glue that holds the divided Amiga community together."

couldn't be supported by any official AmigaOS development, then the community would have to support itself and develop its own AmigaOS. But, if this ambitious project is to be undertaken, then make sure it's done right; make it open-source so that the community won't ever face this problem again, and make it portable so that finding new hardware to run it on won't ever be an issue.

Re-implementing AmigaOS would be no easy task, though. In creating AROS, the developers had to start from scratch, using nothing but the AmigaOS APIs and the collective wisdom of the Amiga community as a guide. The existing OS could not be of any direct help. The complex licensing issues surrounding the various

components of AmigaOS have always made any proposal to open-source it a legal nightmare – even if the current owner at the time could be persuaded.

The principal goal for AROS was portability while remaining as compatible with AmigaOS 3.1 as possible. When run on existing Amiga hardware, AROS aims to be binary-compatible; that is, AmigaOS software will run on AROS and vice versa. On other

architectures, such as the PC, AROS aims for compatibility at the source code level. That means the same source code can be compiled for AmigaOS 3.1 or any of the flavours of AROS (although the resulting binaries obviously won't work on all platforms). Binary compatibility with AmigaOS 3.1 on all hardware would require some kind of emulation technology, and while this problem has been investigated, no practical solution has been found. (UAE has been ported to AROS, for those that need to run legacy software.)

Another goal for AROS was that it should be able to run natively, as a stand-alone operating system, on the target hardware, or hosted as a layer over an existing operating system (currently Linux and *BSD are supported). When hosted, AROS creates an Amiga desktop in a window on the host, much like you'd see when running UAE. The difference with AROS is that only the API is emulated, not any hardware. Binaries run in the hosted AROS run at full, native speed. The hosted flavours of AROS don't require much driver support in AROS, so have been an important tool in developing AROS. It's also handy for application writers using Linux as a development host or for users who want a simple way to try out AROS.

Work in Progress

After eight years of hard work, sometimes with very few external signs of progress, AROS is at last nearing the point where it is usable, if not yet very useful. Although it is still very much in an alpha state, the core – including the AROS clones of Exec, Intuition and AmigaDOS – is largely feature-complete. Work is steadily progressing on implementing higher-level components such as Wanderer, AROS's equivalent of the Amiga's Workbench, and all the tools and utilities that you would expect to find with AmigaOS. AROS has datatypes, commodities, a REXX interpreter

and even its own version of HDToolbox. Since Amiga users and developers have come to rely on various third-party libraries, many of the most common of these have been re-implemented in AROS, including ReqTools and CyberGraphX. There's even an open-source port of MUI for AROS, called Zune, which is used by Wanderer and some of the AROS preferences tools.

Currently, the AROS ports which run stand-alone on the PC and hosted atop Linux on the PC are the most advanced. For Intel-phobes, work has recently begun on a port to the PowerPC for PReP hardware and the Pegasos (Genesi have donated a machine to the project). Interestingly, an experimental port for Palm Pilot also exists.

For those that wish to try out AROS on their PCs, regular development snapshots are available from the AROS web site in various forms, as a bootable floppy image, as an ISO image suitable for creating a bootable CD-ROM, or as a binary package which can be installed and run hosted on Linux. If you want to build binaries yourself, source code snapshots are also available.

The PC-native flavour of AROS currently ships with only a basic set of hardware drivers. This includes support for PS/2 mice and keyboards, standard PC serial and parallel ports, ATA hard drives and CD-ROM drives and unaccelerated support for VESA graphics cards. There's also an experimental hardware-accelerated driver for NVidia graphics cards, and USB support is in progress.

Clearly driver development is an area that still needs a lot of work. Audio hardware is currently not supported at all, although recently Martin Blom ported the AHI system to AROS. Drivers for specific sound cards now need to follow. Other missing pieces are networking and any real applications. Proposals to include AmiTCP 3.0 have been put forward, since the source code to that network stack is available. And, while Lots of example software has been ported to AROS – including tools, utilities and games (such as Doom and Quake) – it's early days still for useful applications.



AROS may be short of real world applications, but plenty of games have been ported to the platform

Divide or conquer?

Now that commercial development of AmigaOS has resumed, is AROS still relevant? Some would even argue that the existence of a third Amiga-like operating system does more harm than good. It fractures a community split over the AmigaOS versus MorphOS debate even further.

Ignoring such questions, AROS is a positive development for the Amiga user. In particular, with the PC port of AROS, Amiga users can take advantage of the unmatched price/performance ratio of modern, off-the-shelf PC hardware as a basis for running an Amiga-like operating system. Moreover, the huge installed user base of PC hardware means that the potential size of the Amiga community has suddenly exploded in size.

But even if AROS never takes off as an end user platform, the project has already contributed much to the Amiga community. Several AROS components were used in AmigaOS 3.9 and many more are used in MorphOS. I would hazard a bet that it has also helped AmigaOS 4.0 development, if only indirectly, as a template for solving the portability problems of AmigaOS.

Given the current divisions in the Amiga community, what role will AROS play? Will a third, binary-incompatible (at least on non-PPC hardware) Amiga platform just confuse users and further discourage commercial developers? Well, it doesn't have to be that way. The open nature of AROS means that it could be the glue that holds the divided Amiga community together. With official endorsement from Amiga Inc, AROS could become the reference implementation for the standard APIs required to make an Amiga-like operating system. After all, from a developer's point of view, at the source code level, AmigaOS 4.0, MorphOS and AROS are all very similar. Why not leverage that similarity and codify it into an open standard that developers can use to ensure that their software can easily be built to run on any of the three platforms?

If AROS can help the Amiga community, why not help AROS? Pop along to www.aros.org, download a copy and try it out. Give the developers your support, your suggestions and your bug reports. Above all, get involved and have fun.

Is it Legal?

Cloning an operating system is a project fraught with legal questions. However, implementing an operating system that clones the API of another isn't actually illegal since an API is not patentable. It has been done before, and it will no doubt be done again. Nevertheless, the AROS developers have had to ensure that AROS doesn't contain any of Amiga Inc.'s intellectual property. For instance, AROS doesn't feature Intuition's draggable screens and pull-down menus (rather these pop up at the mouse pointer's position), which are both covered by Amiga patents. Similarly, AROS can't use Amiga trademarks. Thus AROS's desktop is called Wanderer rather than Workbench.

Despite these and other precautions, AROS may still be in a legally dubious position, if only because Amiga Inc itself has not made any official statement regarding AROS. The fact that Amiga has not sent its lawyers to shut down the project may be seen as unofficial approval. Nevertheless, a clarification of AROS's legal status from Amiga would help raise the profile of and confidence in AROS.

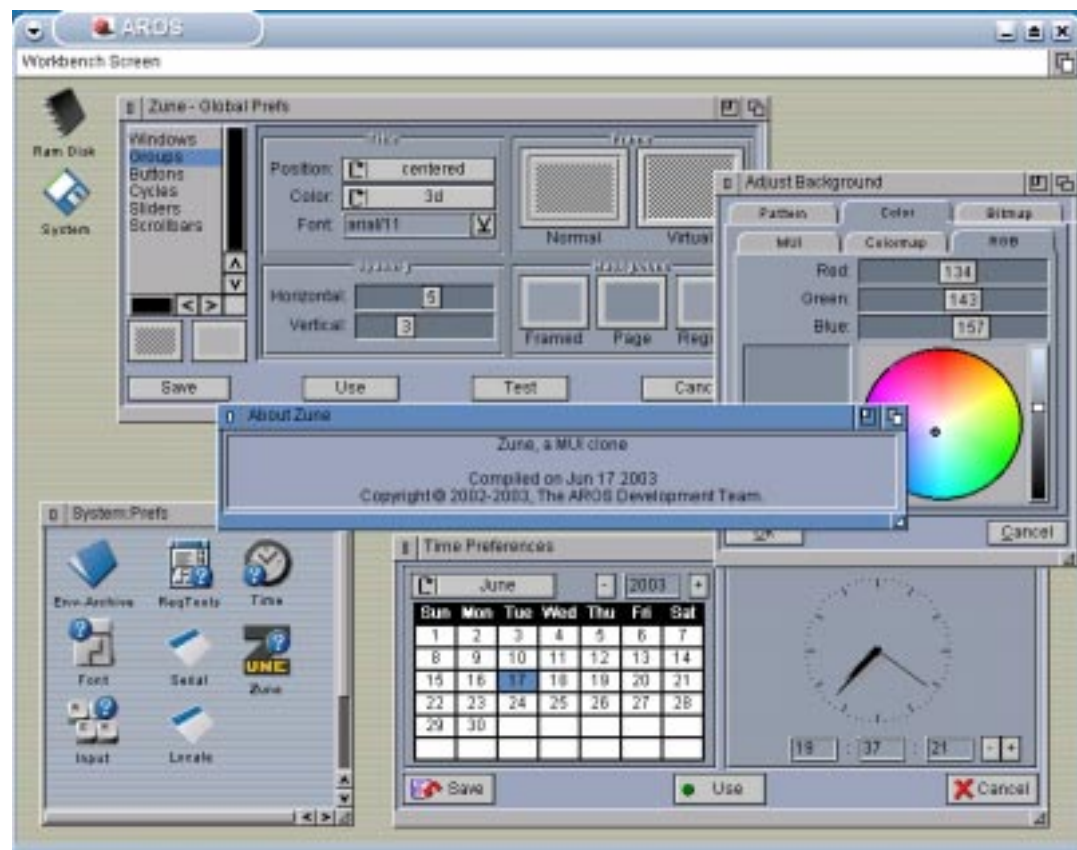

Good-looking and powerful user interfaces can make the transition to AROS now that it features a clone of MUI, called Zune.

Mac: Reloaded

Michael Carrillo discovers 68k Mac emulation is still worth it.

Oh no not another Mac emulation article again! why bother? Abandonware that's why.

Classic Mac emulation has become big on the PC as finally the raw power of the latest Pentiums could emulate a Classic Mac at decent speeds. We on the Amiga have always had the advantage of having the same processor family. i.e. the 68K CPU series. As a result, very many websites catering for mac emulation on the PC have sprung up each containing a wealth of resources or programmes some legal some not so legal available for download. Of course these resources are also open for the Amiga user to take full advantage of.

Mac emulation on the Amiga has been around a long time via such programs as Shapeshifter (Now Basilisk II) and the Fusion Series etc. Of course, if you have an 060 based Amiga you can emulate a Classic Mac (68K) far faster than the real thing as Apple never released an 060 based Mac! Of course not everyone has an 060, This review is coming courtesy of a Dual PPC/040 machine, which is just about suitable, if you have an 030 don't worry you can still get some mileage out of this article.

So what's available? Anything and everything if you know where to look. From classics such as Civilisation, Colonisation and Fury of the Furries, to

games that never made it to the Amiga such as Wolfenstein 3D, Ceaser, Marathon and tons more. Plus a whole world of office software, for example I was at a car boot sale and picked up a copy of Microsoft Office 4.12 for a snip. Now I can run Word, Excel and Powerpoint on my Amiga. Indeed this article is being written on Word 6 for the Mac at this very moment.

Setting up your Amiga to Run as a Mac.

Choose an emulator, from either Basilisk II or if you have Amiga Format disk 134 Try out fusion 3.1. full version. Which is what I'm using. In either case you are going to need a Mac ROM, similar to the Amiga ROMs, in order to get started. Note that just like the Amiga ROMs, you are not allowed to have copies of the Mac ROM unless you physically have a Mac ROM. If you do own one, but cannot get to it, please see boxout for suitable link to where one can be downloaded from. Note if you have an 040 or 060 Amiga you will need an 040 Mac ROM, it won't work otherwise. Set up your emulator of choice, insert the ROM, and you are ready to go, well almost! You are going to need an operating system in order to get that mac up and running. Apple released all their operating systems up to version 7.5.5 for free download years ago. All these OS's and updates are available to download from Apple's own download site

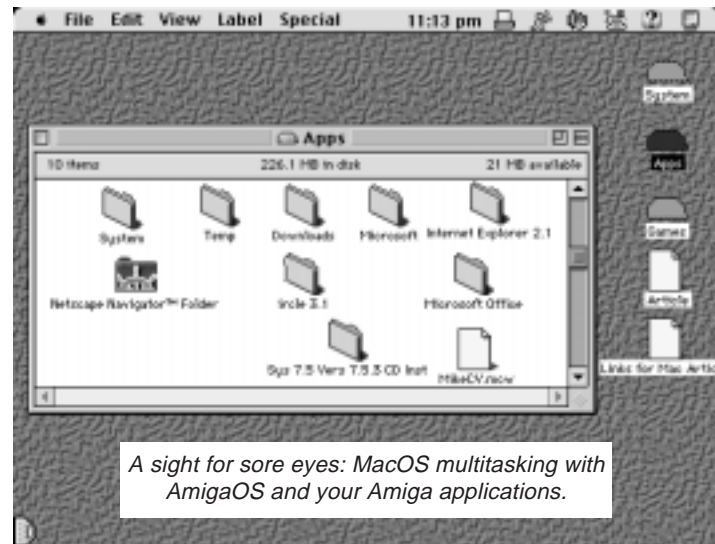

A sight for sore eyes: MacOS multitasking with AmigaOS and your Amiga applications.

Hardfiles vs Dedicated Partitions

Hardfiles

Hardfiles are handy, you don't need to partition or re-format any hard disks, all you do is tell fusion or Basilisk the size of the hardfile in megabytes and it creates one. The minimum you will need is at least 50Mb of disk space, that will give you enough room for the System files plus a couple of applications and games if you are lucky. Be warned that hardfiles are much slower in use.

Partitions

Partitions are much faster, but be warned that if your mac suffers a fatal crash, other partitions can be affected and you could lose them altogether, I would advise you either back up everything you need (This happened to me under Fusion - can't comment on Basilisk), or take the third option of using a separate hard drive.

OptionThree

Use a separate hard disk, for example, I have two Hard disks on my Amiga, a 20Gb and an old 4.3Gb one. Using the smaller hard drive I partitioned it as follows:

- 1: Emergency Workbench (100Mb) Just in case.

- 2: Mac Executables (100Mb) This is where the Fusion executable and Hard Files reside on the Amiga side.
 - 3: Mac System (110Mb)
 - 4: Mac Applications (250Mb)
 - 5: Mac Games (640Mb)
- All in all I set aside 1Gb. Is it worth it? You bet.

Of course when I first booted up I had to format partitions 3-5 on the mac side. Why Partition? Well like your Amiga it's easier to keep things tidy and of course, if one partition goes AWOL, you haven't lost everything.

Tip: Naming your Mac Partitions. Decide from the off which drive you are going to use for transferring files from the Mac side to the Amiga side. For example in Fusion pressing L-Amiga and M switches screens, back to the Amiga side. Once back on the Amiga side there is a little pop up program from fusion, that amongst other things allows you to mount one of your mac drives over to the Amiga side. This has the effect of another hard drive icon popping up on your workbench. Through trial and error I realised that I couldn't call my Mac Applications Partition "Applications" as it clashes with the Amiga's own Applications Partition. Changing it to "Apps" on the Mac side solved the problem.

System Disks at the ready?

Booting Mac OS from CD

If you have a Mac system disk on CD then just boot with that, Macs have auto boot up from CD-ROM built in, handy for when there isn't a system installed on the hard drive.

Booting Mac OS by other means

Fusion

First of all you need a bootable hardfile to get the Mac going. In the Download links section you will find reference to a small very basic Mac OS for Fusion; a 4Mb file. All this does is boot a very basic OS onto the Mac, nearly all features are missing.

Once you have done that, download the System 7.5.3 Install file (British Install, 40Mb). If you have a dial up Internet connection, ask a friend who has broadband to download the file or files for you and put it onto a CD. Please note that you cannot boot from this file it is only for install purposes. Alternatively you will have to download the version from the Apple Download site, ensure that you download the correct country for you, MacOS 7.5.3 comes in roughly at around 16 disks or more. You won't need to copy them to Mac floppies, they are just virtual disks. Double clicking on the first in the series of disks brings them all together into a 40Mb or so Install disk.

Tip: Beware of Mac files, downloaded via another operating system, as they are really fussy and sometimes don't work (it's all to do with resource forks). Best bet is to Download the British Install I mentioned earlier, set up your modem, install Netscape 3.01 and download your specific country OS from the apple website, then re-install the OS once more.

ShapeShifter/Basilisk II

If you are using Basilisk or the older Shapeshifter, Look at CU Amiga CD 21 as it contains a whole suite of Mac hardfiles specific to Shapeshifter and most likely Basilisk. Alternatively, the files can be downloaded as well from the same place as the British Fusion Hardfiles.



68k MacOS has a vast catalogue of useful applications.

Tip: When installing Mac OS under Amiga Emulation, DO NOT choose Easy install, instead select custom, and select install for any Mac or universal Mac. Whilst you are ticking boxes, ensure that under "Extensions", you remove Arose plus any PowerPC Extensions mentioned there and also in Control panel. If the Mac crashes after boot up. Re-boot, wait until Mac disk icon appears then immediately press shift, before Mac dialogue box opens, this will disable the extensions on boot up.

For later Mac OS's Shop around the Internet or Mac Dealers. If you have an 060 you can easily run OS8.2 on your Amiga. OS8 is slower but nicer all round. Note that an '040 based Amiga will easily run 7.6.1 but will struggle with OS8. If you have an '030 stick to 7.5.3 or earlier. Use of a graphics or graffiti card helps speed up the emulation.

Screenmodes

Most classic Mac games require a 256 colour or less (even B&W) screens. Therefore ensure that you have all your screenmodes setup for 256 colours on the Amiga side. i.e. CGX or Picasso.

Tip: If your Mac the screen is off centre, too small or too big etc., it means that you haven't set up your screenmodes properly. Exit the emulator and edit screenmodes on Amiga side. Note Mac OS doesn't have Screen re-sizing setup in the OS.

Utilities and Applications

There are a ton of Utilities and Applications for the mac classic. (all these are free or shareware)

Disinfectant – No longer updated but very useful at catching those old Mac viruses.

Aaron – Nice Eyecandy. Makes your Mac desktop pretty.

Chucks Printer Driver – Will allow you to print via your Amiga.

FreePPP – Replacement Mac TCP/IP, Internet Dialer. Best there is.

OpenTransportPPP 1.1.1 – Available from the Apple site, you'll need this to get on-line.

Netscape – Available from the Netscape Site, Use Netscape 3.01 and then experiment with versions 4.01 to 4.08. as they are prone to guru your Amiga completely.

Tip: When you have installed your OS on the Mac, find out how big it is, (click system icon), then exit emulation, create

Links

Amiga Emulators

<http://www.uni-mainz.de/~bauec002/B2Main.html>
Basilisk II Mac Emulator

<http://homepages.ihug.co.nz/~miles.j/shape.html>
Dated, but still useful Amiga/Mac Emulation page, gives hints and tips on getting the Mac working on your Amiga.

Official Software Downloads

http://download.info.apple.com/Apple_Support_Area/Apple_Software_Updates/
Apple Downloads – Find the specific OS for your country.

http://download.info.apple.com/Apple_Support_Area/Apple_Software_Updates/English-British/Macintosh
British English OS download.

http://wp.netscape.com/download/archive/client_archive.40x.htm
Netscape 4.0x Downloads

http://wp.netscape.com/download/archive/client_archive.30x.htm
Netscape 3.0x Downloads

<http://www.sbceo.k12.ca.us/helpdesk/helpsoftware.html>
FreePPP and other helpful Software

For many more links check out the resources section for this issue on the Total Amiga website:
<http://www.totalamiga.org/issue15.html>

another hardfile, and copy System to it. That way, if anything goes wrong, it's easy to get back in.

Tip: Click on a program icon select Get Info from Mac Edit Menu. You can increase the program's memory requirement size. Useful for Netscape, all versions.

Fusion Warning

Finally, if you are using Fusion and you transfer files from your Amiga to the Mac as mentioned earlier, make sure you dismount the Mac partition off Workbench before returning back to the Mac emulation. Should the Mac crash, it won't be so painful. Always remember to shut down the Mac properly, you cannot just switch your Amiga off and walk away. Select from the Apple menu (Click on Apple Icon on top menu bar) "Shut Down".

As always, if you have any questions, please post them to totalamiga@yahogroups.com.

Alternatively if you can't wait call in via IRC to #amigaworld on Undernet servers, or by visiting <http://chat.amigaworld.net/chat>.

Try out classic game that never made it to the Amiga.



The Legend Continues...



Embrace Digital Living

AMIGA[®]
<http://www.amiga.com>

Quake II Competition!

Win a copy of Amiga Quake II
courtesy of Hyperion Entertainment
and Fore-matt Home Computing

The Questions

- A. Which Amiga model has "JUNE BUG" printed on its motherboard?
- B. What was the name of Jay Miner's dog during the Amiga's development?
- C. How many back issues of Total Amiga can be freely downloaded from our website?

Send your answers by EMail to: competition@totalamiga.org

Include your: name, postal address and EMail address.

Alternatively post your answers to:

Total Amiga, 26 Wincoat Drive, Benfleet, Essex, SS7 5AH, UK



<http://www.hyperion-entertainment.com>



<http://www.forematt.co.uk>

Competition Rules

The winner will be drawn from all the correct entries received by the 18th of August. The draw will be held on the 23rd of August 2003 and the winner notified by EMail (if available). Total Amiga contributors and members of the organisations involved may not enter this competition. Only one entry is allowed per household. The prize available is one original copy of Quake II for the Amiga, no alternative is offered. Decisions on correct answers and the draw will be made by Total Amiga staff, their decision is final and no correspondence will be entered into. Your details will be used by Total Amiga to administer this competition, they will not be passed to the companies involved or to anyone else.

Pegasos

A new PPC based computer that runs Amiga software tempts Sam Byford.

MorphOS

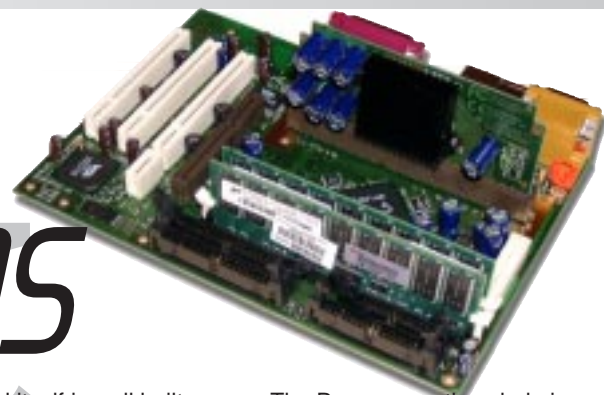

A war rages in the world that is Amiga. Choosing between an AmigaOne or a Pegasos for your next generation machine is a big decision. First impressions and reviews of a platform and its operating system help people to decide which way to go and this month we bring Genesi's Pegasos and MorphOS into the limelight.

This review is based on a Pegasos I motherboard with the April2 fix and MorphOS version 1.3. This is classified as a Beta OS by Genesi so there are a fair few bugs inherent in the system. Version 1.4 is due out within the next few weeks and this should rectify some of the problems which I will mention in this article. No doubt it will also introduce some new ones.

I ordered my Pegasos from the UK reseller who has a web site at <http://www.pegasos-uk.com> but you can also order from any of the other resellers, including

.info

Developer
Genesi
www.genesi.lu

Distributor
www.pegasos-uk.com

Price
Motherboard with MorphOS and Linux..... £377
Discounts may be available for developers.

Test System
Pegasos with April 2
PPC G3 CPU @ 600Mhz
512Mb RAM
ATI Radeon 7000LE AGP
ATX Tower Case

MorphOS 1.3

straight from Genesi themselves. Each dealer has their own software packages or full systems available. Mine was just the basics: the Pegasos motherboard itself including a blanking plate, MorphOS on CD and a A4 Technical Specifications "manual", all for the princely sum of £378 (free shipping). Now that is a lot of money for a system, especially as you also need a tower; memory; CD-ROM etc. For a similar amount you could put together a decent PC system. But we have got used to paying over-the-odds for things in our "alternative platform" and hopefully the more machines they sell the more the price can drop.

I find the A4 sheet they call a manual rather disquieting: a machine like this should come with a proper manual, with full instructions on paper, showing how to get it up and running and all the ins and outs of its system (the Amiga 4000 came with four large tomes). Once you have done the initial boot into MorphOS using the CD these items are available in PDF form but the less able of users out there should have these in their hands from the start.

The Hardware: Pegasos

When you see the size of the motherboard you can't help but be impressed. At 236mm by 172mm it conforms nicely to the micro-ATX specifications and as such will fit into pretty much any tower you can lay your hands on. Beware of the low profile (3 inch) cases though – with some of the larger AGP or PCI cards (such as the Radeon 9000s) they are too tall and you will not fit them into the machine without an angle-adaptor which usually costs around £25. For that money you may as well just buy a slightly larger case which lets you use the cards in their normal slots.

The board itself is well built on the whole, with all components solidly in place and a fairly logical layout. There are two things that I noticed with the board: the first is that the MIC connector is about an inch too far away from my towers front panel so that the lead will not reach. This will differ system to system and is an easy enough problem to overcome. The second thing is that the IDE and floppy connectors have securing clips which I feel are not required as the cables stay in place by themselves without any help. They are also made of a plastic that breaks far too easily if you

"In my setup the only noise is the CD-ROM and a slight purr from the PSU!"

use too much pressure when inserting your cables. Within five minutes of having my board one of those clips broke off giving me a mild panic attack.

The blanking plate that was provided with my Pegasos is made of aluminium and is rather flimsy. I would have liked a slightly thicker and stronger blanking plate, similar to the one that came with my case. It does the job however and fits nicely around all the sockets.

The Pegasos I, which has currently sold out, is not as advanced as the Pegasos II which should be available sometime later this year with upgrade offers available to those already owning an earlier version of the motherboard or CPU. My current system comes with a G3 600MHz PowerPC (750 CXe) processor which runs incredibly cool and silently. Unlike almost all PC processors which require very big heatsinks and fans the G3 runs with only a small heatsink and no fan. The Radeon 7000 AGP graphics card I have installed gives off even less heat than the G3 which is also unusual!

The Pegasos on the whole is so quiet and efficient in what it does that you can quite easily leave it turned on permanently. Its basic power consumption is a mere 7 Watts compared to PCs which use at least 20 Watts (figures taken from the PowerPC web site). In my setup the only thing that gives off any noise is the CD-ROM and a slight purr from the PSU. Such a small power consumption combined with the minimal noise and heat output means the Pegasos is a much nicer machine to leave running for long periods of time than any other system I have used.

I have two 256Mb RAM chips

installed into the PC133 slots giving me 512Mb of memory, though a total of 2Gb is available. Unfortunately the Pegasos currently appears to be continuing the Amiga trend of needing to use specific types of memory, but as long as you stick to using Registered PC133 RAM you should be alright. The Pegasos II will use a new northbridge chip developed by Marvell (to replace the Articia Northbridge) which works with many more types of memory. In the meantime a growing list of the working and non-working RAM that has been tested can be found at the MorphZone website.

The Pegasos comes with a floppy drive connector but MorphOS has no drivers to use it. Linux, however, does have drivers but will only read PC/Linux disks so if you want to use a floppy drive (be it an Amiga or a PC/Generic one) with your MorphOS system you will need to purchase a Catweasel from Individual Computers. The reason given for this is one of "we have more important things to code and floppy drives are not a priority" (note: not a quote!).

There are two ways to look at that – the first is that they are right; you don't need floppies so much now days. Most people who own two or more computers will have a network and FTP of some sort set up so transfer of data is easy. The second is that this is a basic and fundamental part of a system (unless you own a Mac). While making the code for floppy access will take time away from doing more important things once it is done no more time needs to be spent on it. Adding floppy support also stops the nagging from the users who want this feature.

For those of you who are selling off your old Amigas, keep hold of your hard drives as they will almost certainly work straight off when plugged into the Pegasos. Whether the programs run is another matter entirely but the drives themselves will be recognised and used. Pegasos and MorphOS have built in support for both FFS and SFS and can also run PFS hard drives so most setups should work. For those of you with SCSI drives the Symbios PCI-SCSI cards will work with Pegasos and MorphOS. Good news all round!

The Pegasos uses an in-built system called OF (Open Firmware) which is similar to the current Amiga Kickstart (but without the menu system) and the PCs BIOS. It has a full knowledge of all the hardware in the computer. At boot you can access OF to set boot options

and to boot into the different OS's that are installed on your computer (there are currently no OS selectors available like those written for PCs). One problem to be found in the current OF is connected to mice: if you move a plugged in PS2 mouse while in OF it will produce an error and stop booting. Most of the time hitting Enter a few times will rectify this but on occasion you have to power the computer down for a second or so then restart. This problem is being looked into so expect an update to rectify this sometime in the near future.

The Operating System: MorphOS (1.3)

Before I launch into the pros and cons of MorphOS (MOS) there is one vital bit of data you need to know in order to actually boot your Pegasos using the MOS CD for the first time: the command printed on the CD case is wrong and may not work. The case (and indeed the MOS quick-start guide) states that in OF you should type "boot /ide/cd boot.img" but this will give an error message of "error: no filesystem recognised". Instead you should use the following command, "boot /ide/cd@0,1 boot.img" this is assuming that the CD drive is on the slave connector of the first IDE channel. If it is on the second IDE cable you would use @1,0 or @1,1.

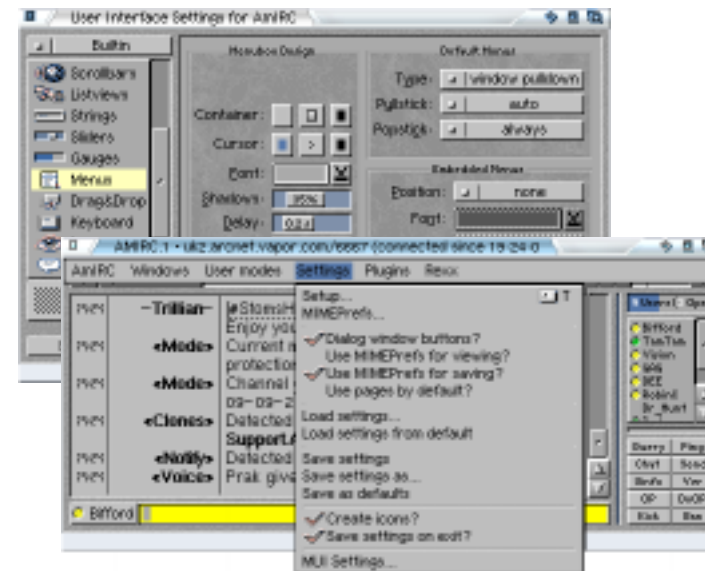

One of MUI 3.9's new menu options demonstrated in AmIRC.

Once you have booted into MOS using the CD you are presented with a basic Ambient desktop (Ambient is MorphOS's version of Workbench) in quite a small resolution so that it works on all monitors. MOS looks very nice even at its basic level, with nice PNG icons (though a bit on the large side). There are instructions in readme format that explain how to partition and format your hard drive ready for MOS installation. Once that is done copy the boot.img to the correct partition and the CD contents to the drive then reboot the machine. At this point you have to know what to type into OF to tell the computer to boot into MOS automatically on reset, so you'll need to have written down the instructions from the

readme. This is another reason for having a good printed manual to hand.

I found that with my 80Gb hard drive MOS would only recognise it as a 8Gb drive no matter what I did. My solution was to plug it into my A4000, format the drive as one big 80Gb partition (quick format worked fine) then transfer it back to the Pegasos. From that moment on it was seen full size. I have heard other users say similar things but some have had no problems so I guess it is down to the individual hard drive that is used.

Applications

Integrated into MOS are PPC native versions of many programs, including AHL and MUI 3.9. This has many improvements over 3.8, not least of which is the facility to change the layout and position of the system menus (for both Ambient and individual programs). In the Menus section of MUI you can set style options similar to that used in MagicMenu. Right mouse button menus can have their location and behaviour set to one of five styles: OS Menu (normal right click, menu at top of screen); screen or window pull-down; mouse pull-down or mouse pop-up. You can also set these menus to sticky so that the mouse button does not need to be held down during selection. The window pull-down option can display the menu items at any of the four sides of its window. Quite a nice little feature and just one of the improvements in MUI.

Pegasos? MorphOS?

MorphOS is a PowerPC-native operating system which is able to run 68k Amiga applications using a built-in emulator. It was originally conceived as a way to move AmigaOS to PPC at a time when Amiga's ownership was in flux and then under Gateway when they were taking a different direction. The original beta release ran on Phase 5 CyberStorm and Blizzard PPC accelerators but used only the PPC processor. The operating system is structured so that resources such as libraries can be ported to PPC and used in conjunction with legacy 68k components allowing for a gradual transition. The key developers of MorphOS are Ralph Schmidt, who developed driver software

for Phase 5, and Frank Marak, the author of CyberGraphX. The Pegasos is a PowerPC motherboard based on the Mai Artica S north bridge. Among other features it has built-in sound, Ethernet, USB and Firewire as well as the standard ports you would expect. It has an AGP 2X slot for a graphics card and three PCI slots. All this is packed onto a compact MicroATX-sized board. A CPU slot allows different PowerPC processors, mounted on a custom card, to be fitted. At the time of writing all Pegasos machines have been supplied with a 600MHz G3 processor card but a faster G4 is due to be released soon. The Pegasos was designed by bplan, a

German company employing several ex-Phase 5 engineers. Over the last couple of years MorphOS has been ported to run on the Pegasos hardware. A great deal of work has gone into removing dependency on AmigaOS components to make MorphOS a stand-alone product while retaining compatibility with Amiga software. In 2002 Thendic France became the sole distributor for the Pegasos and MorphOS and at the beginning of this year they merged with bplan to form Genesi. Since September 2002 Pegasos machines have been available with MorphOS for a period of public beta testing, the latest version (at the time of writing) is reviewed here.

Also in native PPC format are MysticView, APDF and Voyager. Both MysticView (picture viewer) and APDF (PDF viewer) run flawlessly, and extremely fast. They load large files almost instantly and can zoom and manipulate those files with little or no trouble at all. Voyager, when I tried to use it, still seemed bug-laden and crashed me several times (sorry Vapor team!). I suggest installing IBrowse and/or AWeb and using those instead. Also included in MOS are PPC datatypes and if you do install IBrowse ensure you set it to use the external ones, not its internal versions or every page you load will take minutes rather than seconds.

Two PPC games are included in the 1.3 distribution as well: MorphTris, a basic Tetris clone (and hardly worth bothering with) and BirdieShoot, by Epic Interactive Entertainment. This is a somewhat pointless, but nevertheless highly entertaining and addictive, game where you have to shoot down birds of all varieties in four different levels. Beautifully executed, the game has very smooth scrolling and stunning visuals. BirdieShoot could well keep you going back to play time and time again.

There are certain parts of AmigaOS 3.5 or 3.9 that you have to manually copy over to the MOS system, AREXX and Installer being the main two (make sure you use Installer version 43.3). As yet there are no PPC-native versions of these files. Full installation details for AREXX can be found on the MorphZone website.

68K Speed

Timings from ArtEffect 4 to compare MorphOS 1.3's current 68K emulation to an Amiga with a 68060 CPU. A large increase in emulation performance is expected with the new JIT 68K emulator.

A4000 060/50 MOS G3

Load Picture (from RAM)
12 secs 16 secs

Rotate 90° Clockwise
4 secs 2 secs

Colourize: Alien
30 secs 15 secs

Pixelate Median Colour 5x5
2min 39 secs 2min 21 secs



My Ambient desktop with Miami, AmiNetRadio, Frogger and MysticView running.

There are, at the moment, some basic programs missing from the MOS package, most of which are going to be included in future packs. Such things as a basic TCP stack and a text editor are noticeable by their lack of presence. Not having a TCP stack on first install makes setting up a network something of a headache, especially as current versions of AmiTCP do not work on most people's setups. The best program to use is Miami Deluxe but that is not available to buy any more. The good news is that a much-improved PPC native Genesis stack (that will work with ADSL) is on its way. Dietmar Eilert is currently porting GoldEd to MOS which will be now be called MorphED and should become the basic text editor that MOS needs so badly.

An OEM (licensed) version of the USB stack, Poseidon, has been ported to MOS, however at the moment you have to download the archive separately. In future MOS releases it should come pre-installed.

The MorphZone website has a thread detailing what programs users would like to have in MOS releases and the PegasosPPC site has a list of programs that will soon be included in the default package.

MOS1.3 Bugs & Problems

To be honest, I could easily fill this entire edition of Total Amiga with a long list of all the bugs and problems myself and others have found in this version of MOS. But that would be pretty pointless. This is a beta OS

(albeit one that has been around several years already) and you have to expect problems. A lot of the faults are fixed in 1.4 so I have been told, but there are a few issues with 1.3 that I will point out: at the moment the drivers for the Radeon graphics cards are not fully complete – they have 2D but not 3D capabilities. There are also numerous bugs in these CGFX drivers, for example icons do not get redrawn properly after certain actions are taken and two out of three of the dragging effect settings do not work right. When you snapshot or refresh one directory all the icons of the other directories also refresh and not all icons will be snapshotted by a "snapshot all" command.

There also appears to be a problem with icon positioning. At the moment there is only a "Sort by Name" option. When that is used the text of the icons often overlap and the far left hand ones have their text half off the window's edge. Another icon problem shows when you manually move an icon from the far left of a window to the right. The OS still thinks that the original space is occupied and leaves the scroll bar showing something over to the left even though nothing is there.

Relating to fonts, when you use a font requester it does not automatically highlight the currently used font and size, a slight oversight. I have found a program or two that refuses to see a font even though it is present in the system.

Any program that currently only uses audio.device and not AHI

will refuse to play any sound and may not even work at all. A basic work-around for this is being written but if the program using audio.device has been written to "bang the hardware" of the original Amiga then it is very unlikely it will ever work correctly on MOS.

New Functionality and Old New Problems

MorphOS runs on top of the Quark microkernel and initially has two implementations of the OS, the A-Box and the Q-Box. Currently only the A-Box is available to the users. The A-Box provides a re-implementation of the AmigaOS (3.1) for PPC hardware. It includes an emulator to run classic AmigaOS RTG software and the parts of the system that are not yet PPC-native. The Q-Box will be fully PPC-native and aims to provide a more modern OS environment, introducing features that have been sorely lacking on the Amiga such as proper memory protection. Programs for the Q-Box will need to be written specifically for this OS.

Currently 68k programs run under emulation at roughly 060 speeds. When running ArtEffect each operation takes practically the same amount of time on both my A4000 060/50 and my MOS system. Exact figures are shown in the table on this page. A JIT emulation layer is in production which should make even 68k applications fly. Also any current WarpUP and PowerUP programs should run (but might not) and of course native MOS PPC programs will all work nicely.

The basic system of MOS got me somewhat puzzled initially. When I used the CLI to do things like copy it would work fine, but when I looked into MorphOS:C/ most of the usual files were not present. I realised there was another MorphOS directory inside the top level, and inside that there was another set of system directories (e.g.: Morphos:Morphos/C/). These directories contain the PPC native versions of files while the top level ones contain any 68k programs that have not yet been written for PPC.

When you download programs that have been cross-written to

work with 68k and PPC systems you may notice two copies of the same file, one with the prefix .elf on the end. This is the PPC executable and will be ran instead of the 68k version whenever the program is called. There is no need to delete the 68k version and rename the .elf file as MOS is intelligent enough to automatically run the .elf file.

I've already mentioned that MUI has integrated a few of MagicMenu's traits. Another program that has borrowed from past "hacks" is the CLI, which now includes most of KingCON's properties including file completion, drag-and-drop and scroll bars. It also has the ability to "detach" and create a "new" shell by selecting a button in the top of the CLI window. Definitely a good addition to the OS.

With MOS comes the ability to Skin your windows, drawers and programs. Look in MorphOS:Prefs/Presets/Skins/ and you will find a default directory containing numerous files which MOS uses when it has those items open. Thanks to Targhan (the MorphZone webmaster) there is now a program that will extract a skin archive, put it in the correct location and change which skin the OS uses (this requires a reboot). Take a peek at the skins screen-shot for an example of some of the available styles.

Some of the programs which run flawlessly under MOS include

Links

<http://www.morphos.net>
Background information on MorphOS itself.

<http://www.morphzone.org>
MorphOS news, forums, links and screenshot gallery.

<http://www.pegasosppc.com>
Detailed information on the pegasos and OS support.

<http://www.morphos-news.de>
MOS news and discussion.

<http://www.openfirmware.org>
Find out more about the Pegasos firmware.

<http://www.ami.ga>
Individual Computers with their Catweasel controller.

IRC Server
ch1.arcnet.vapor.com
Channel= #MorphOS

SimpleMail, though I found that when this is run on a Dopus Magellan screen it loses all its icons; AmiNetRadio; FeebleFiles; FroggerNG (includes PPC codecs so it runs nice and fast); FTPd and AmigaAMP. MorphZone carries a list of programs tested and a links section which I maintain.

Going back to Dopus Magellan (5.82), this is a program that runs almost perfectly on MOS. Its main drawback is that it can not display PNG icons, which MOS uses as default. Any PNG icons (such as Ram: hard drives etc.) show up as an "Ambient PNG" default icon and are non-clickable. You can still thankfully drag-and-drop archive files to those icons to un-archive them but otherwise they are useless. I have taken to showing only the RAM: icon for just this reason and have Dopus permanently set to load as a separate screen rather than as a replacement Workbench. The way around the icon problem is to rename the

"The look and feel of MorphOS is distinctly Amiga ... with one hell of a speed-boost."

icon.library in Morphos:morphos/libs/ and insert the Amiga OS3.5/3.9 icon.library into the Morphos:libs/ directory instead. That makes older icons display correctly, however PNG icons will now not display properly in MOS. Quite a drawback and one I personally am not willing to suffer. Listers work properly under Dopus so you still have full functionality in that respect.

I have been told that games such as Quake I/II run fine under MOS, but I have been unable to prove this. Although I have a fair few of these sort of games I find that I am unable to install them due to a rather annoying problem with Installer. There appears to be a size calculation error which means that when a program checks if there is enough space left on a drive it does not see that my hard drive has 70Gb of space left, it sees 230Mb and refuses to install. This is not just a MOS fault though as I had this problem with some programs (WordWorth) on my A4000 too. It just appears that more programs fall foul of this bug than before. Even InstallerNG appears to have the same problem and it means I have been unable to install and test Quake,



Some of the skins available to customise the window look.

WordWorth and AmigaWriter. A PPC-native MOS Installer needs to be written, or InstallerNG given an overhaul.

Conclusion

MorphOS 1.3 has a lot of faults, there's no denying that. But it is nice, very fast and it has one hell of a lot of potential! If the screen-shot that was posted to the news sites recently showing off MUI's new features is anything to go by

of some sort when it arrives. And the real test will not come until the Q-Box is in development. For now, though, MOS is usable, albeit alongside either an original Amiga or one of the better emulators running on MOS or a PC. It still remains a sad fact that at this time a lot of old Amiga applications refuse to work properly on MOS, but a fair bit of the cause of that is improper coding on the part of those writers, and in any case UAE runs perfectly on MOS.

Initially this is an awkward OS to set up, but with the integration of network and editing software into 1.4+ this should become less of a problem. Has there ever been a true Amiga user that hasn't smiled at a challenge of this sort? The hardware is fast and on the whole is up-to-date (even more so when the Pegasos II arrives) and should not provide legacy problems in the future.

So to all those people out there who don't like to think of the Pegasos/MorphOS as an Amiga I say think again, the look and feel of MOS is distinctly Amiga, just a nice new, clean, Amiga without the hacks and with one hell of a speed-boost.

Watch this space for future reviews of MOS updates and MOS programs/games that should start to appear within the next few months. The revolution has just started.

Results

- Pros**
- + Fast!
 - + Runs many Amiga programs.
 - + Constantly updated.
- Cons**
- Expensive
 - Beta OS
 - Hardware dependant programs don't work.

Pretty Good!

IBrowse 2.3

Version 2.3 has taken ages to mature. Robert Williams takes the taste test - is this a fine vintage or vinegar? Read on to find out!

.info

Developer

Stefan Burstroem and the IBrowse team.

Distributor

IOSpirit
www.iospirit.com

Price

Full..... 54.99E (£38)
1.x Upgrade.... 34.99E (£24)

Requirements

AmigaOS 3.0
68020
6Mb free RAM
MUI 3.8

Recommended

AmigaOS 3.1
68040
10Mb free RAM
Graphics card

Test Systems

A3000
CyberStorm PPC/060
A1200
Blizzard PPC/060
Amithlon
Athlon XP 2000+

IBrowse 2.3 works with many more sites than 2.2.



In the last few years a web browser has become one of the most important applications for any computer system in almost all environments. Over the same period the standards used on the web and browsers on other platforms have been developing rapidly. On a minority platform, like the Amiga, with small development teams it has proven difficult to keep up with the rate of development. IBrowse in particular hadn't seen an update since March 2000, leaving it behind the times and incompatible with a growing number of web sites.

After some time in limbo IBrowse's main author, Stefan Burstroem, resumed development, resulting in this new version, IBrowse 2.3. Registered users of IBrowse 2.0 and above can download a free update. A discounted upgrade is available for 1.x users; a full copy is also available for purchase. IBrowse sales are now being handled by IOSpirit via their secure web ordering service. A limited demonstration version is available for download which, sensibly, includes SSL support. You can use the demo version to purchase IBrowse online from IOSpirit.

On first loading the new version, it's hard to spot any differences from 2.2, especially as it uses

your old preferences file if you upgrade an existing installation. In use it becomes clear that most of the work has happened under the skin.

HTML

There have been no major changes to IBrowse 2.2's HTML rendering in this update. Nevertheless, version 2.3 incorporates a number of tweaks and enhancements that fix a few bugs and improve its rendering of pages with common HTML errors. A noticeable improvement is that many more character entities are now supported, as is automatic mapping of Windows and Mac character sets to the Amiga. Resizing frames by dragging their borders, which had been broken in several versions, now works again. A bug that stops the last item in a list from being indented still exists in version 2.3 because of the amount of work required to fix it. Altogether IBrowse 2.3 very nicely displays most sites that use plain HTML. Browsing seems nice and fast, and the already speedy table rendering has been optimised even further.

CSS

An important part of current HTML standards still not supported in IBrowse 2.3 is cascading style sheets. CSS is a

method used by web designers to set the styles of their page elements, including fonts and text colours used. This standardised framework can replace the various style-related tags that have been added to HTML over the years. The lack of CSS support means some pages are not displayed with all their formatting in IBrowse, but due to the nature of CSS, you should still be able to see all the information. The IBrowse team has announced that they are working on version 3, which will

"...this means that the JavaScript on many more sites now works."

include CSS support. It is great to hear that their development efforts are continuing. It's worth noting that CSS support is a tough nut to crack; even the big browsers such as Internet Explorer and Netscape only offer partial CSS level 2 support and their implementations differ.

Tip: Some sites that use CSS also include some HTML styling tags, which can make the sites unreadable in IBrowse. For example, black text could be displayed on a black background. In these cases try choosing "Custom Colors/Disable" from the "Preferences" menu and reloading the page.

Flash...Ah Ha!

IBrowse does not currently support Macromedia Flash animations, which are used to a greater or lesser degree by many sites. The plug-in interface also has not yet been fully implemented, so a Flash plug-in cannot currently be written by a third party. This means that Voyager is still the only Amiga browser that can play Flash animations embedded in a web page. Version 2.4 of IBrowse is in the works and is planned to have Flash support.

JavaScript

One of the main weaknesses of earlier versions of IBrowse 2 was their JavaScript support. JavaScript is a scripting language that allows a web designer to control aspects of the web page and the browser itself. JavaScript is used for tasks such as verifying data entered into forms, creating dynamic pages that change without reloading, and for more frivolous features such as graphics that change as you roll your pointer over them. Many pages rely on JavaScript in one form or another, so IBrowse's weakness in this area made it unable to access some sites.

Note: JavaScript and Java are two different things. Java is a stand-alone programming language that can be used to produce "applets", small applications that run within a browser. Currently IBrowse does not support Java applets.

In version 2.3 IBrowse's JavaScript support has been extensively overhauled, reworked, and tested on many web sites. The JavaScript engine is now compatible with the latest JavaScript and ECMAScript specifications. In effect this means that the JavaScript on many more sites now works.

"AmiSSL 2 is free and works with Miami and Genesis"

JavaScript that commonly caused IBrowse 2.2 to fail, such as links that run scripts to open a new page and image rollovers, now work on the vast majority of sites. The remaining unsupported JavaScript features are largely due to IBrowse's lack of CSS support; the authors plan to address these features in version 3. There are still a few sites whose JavaScript does not work in IBrowse. Usually these sites either involve poorly written JavaScript or exploit nonstandard quirks of a specific

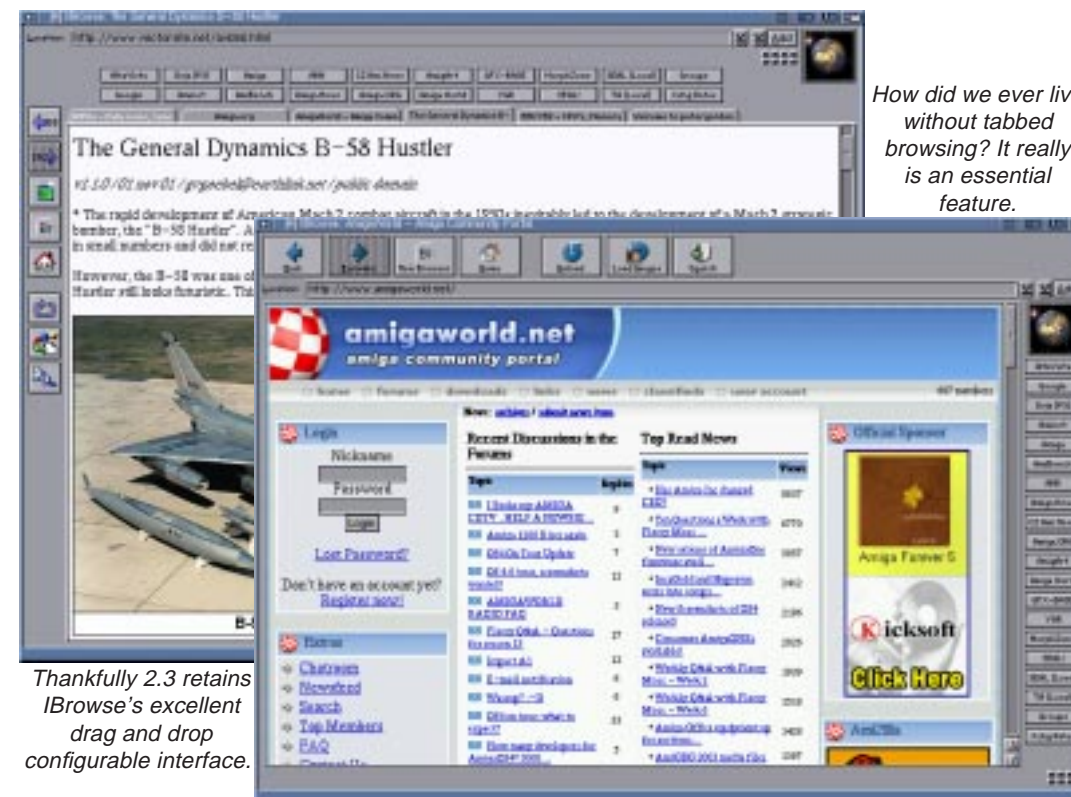

Thankfully 2.3 retains IBrowse's excellent drag and drop configurable interface.

How did we ever live without tabbed browsing? It really is an essential feature.

browser. In IBrowse 2.2 broken JavaScript code could put the browser into a loop effectively locking it up. Version 2.3 has an option to warn you after JavaScript has been running for a user definable length of time so you can break out of the loop. A new preferences option has been added so you can prevent the annoyance of JavaScript embedded in a page moving and resizing your browser window.

Some web sites are designed only to work with certain browsers. These checks can often be counterproductive by blocking access to alternative browsers that would work perfectly well with the site. To get around these problems many

browsers offer a "spoofing" option in which the browser identifies itself as one of the common browsers such as Internet Explorer or Netscape. In IBrowse 2.3, spoofing has been improved to send a more compatible browser identification string. Spoofing still has to be enabled on a site-by-site basis using the URL Prefs. The URL Prefs option enables you to set different combinations of options for specific web sites. IBrowse doesn't have the selection of spoofing options found in AWeb and Voyager, but the new string does work on many more web sites. Importantly IBrowse now also spoofs its identity through JavaScript too, allowing many more sites to work than before.

Security

IBrowse 2.2 implemented access to secure web sites using the SSL (Secure Sockets Layer) module for the Miami TCP/IP stack. This worked well but had the disadvantage of only being available to registered Miami users. In recent years the situation has become even worse because it is no longer possible to register Miami. Version 2.3 can still use Miami SSL, but it also supports AmiSSL 2, which has been developed from version 1 by Stefan Burstroem. AmiSSL 2 is available free and works with Miami, Genesis, and other compatible TCP/IP stacks. It is also based on the much more up-to-date SSL code, so it should be compatible with more secure servers. Control over AmiSSL is built into IBrowse's preferences window and includes facilities to load and save SSL certificates and to enable and disable different encryption cyphers.

The combination of improved JavaScript and enhanced security means IBrowse can now access more secure sites such as those offering online shopping and banking.

Interface

Thankfully, version 2.3 retains IBrowse's user-friendly and

Bank Onlinewith IBrowse

We asked members of the IBrowse mailing list to report online banks which work with IBrowse 2.3. The following banks were reported working as of May 2003. Many others may work, these happen to be used by members of the IBrowse mailing list:

- UK**
 - Abbey National
 - Barclays
 - Egg
 - Halifax
 - HSBC
 - LLoyds TSB
 - MBNA
 - NatWest online
- USA**
 - First Union/Wachovia
- Sweden**
 - Nordea
 - FöreningsSparbanken
- Canada**
 - RBC (Royal Bank Canada)
 - CIBC (Canadian Imperial Bank of Commerce)
- New Zealand**
 - AMP Banking

efficient interface. You can customise the position of all the objects in the IBrowse window, including the toolbar, fastlink buttons, and even the status bar and location gadget. Drag-and-drop is implemented everywhere. A handy new feature is that when you drag a link onto the fastlinks bar, a requester pops up so you can edit the name of the new button.

Tabbed browsing - which has been added to many browsers including Netscape, Mozilla and Apple's Safari - has been a feature of IBrowse since 2.0. This allows you to open several web pages in one browser window each being displayed with a tab at the top. Tabs eliminate the need for a clutter of browser windows. As I

"The improved support for JavaScript and SSL has made accessible many sites that were previously denied to IBrowse users"

mentioned in last issue's Top Tips, tabbed browsing has been extensively improved for version 2.3 and is now an essential feature. You can open a new tab from the menu, and there is also an option to open a link in a new tab in the right-click contextual menu. If the tab bar is showing, you can even drag a link onto an existing tab to replace the page or onto the space at the right of the tab bar to open the link in a new tab. By using drag-and-drop, you can reorder the tabs in the browser window, open a tab as a new window, and even move tabs between open



IBrowse Cache Explorer lets you view pages offline and selectively prune your cache.

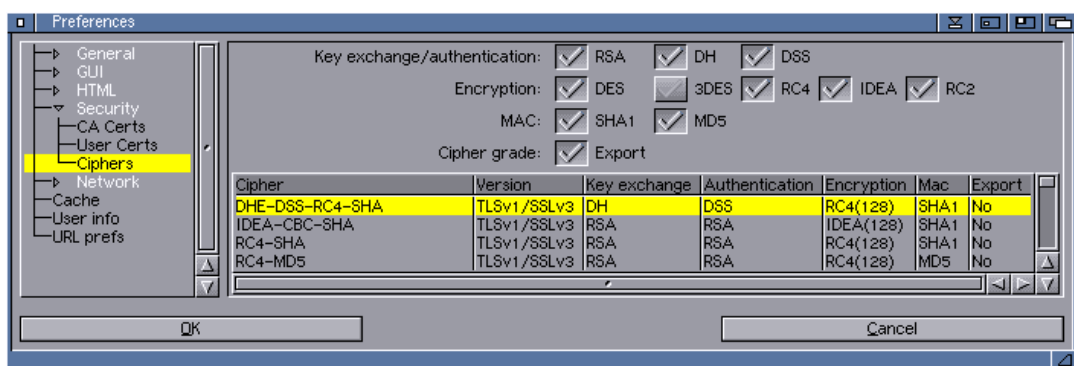

windows. Tabs can be dragged into the fastlink bar and into the bookmarks hotlist too. The only feature I would like to see added is the facility to background-load a link so that a new tab opens but is not selected. The improvements to tabbed browsing seem to have been carefully thought through. Once you're used to opening multiple tabs, it is hard to go back to a browser that does not offer the feature.

Some other aspects of the user interface have undergone minor tweaks to make them more logical and easier to use. The preferences window has been tidied up, and some options that were never implemented have been removed. New preferences options relating to the new features are now included. The main program menus and some of the pop-up contextual menus have been slightly reordered and renamed as well.

Downloading

IBrowse's handy download manager has been further enhanced. It now remembers failed or incomplete downloads between sessions, and it allows you to restart them the next time you are online. The detection of incomplete downloads has also been improved, making this feature even more useful. IBrowse has a built-in resume facility (as long as this is supported by the remote server), so it is able to download just the remainder of an incomplete file.

Printing

Unfortunately, graphical printing to non-PostScript printers has still not been implemented in this version, and text printing is still very basic. PostScript printing has had a few minor tweaks, and the problem that version 2.2 had with printing larger images has been resolved. A progress

Above: AmiSSL preferences built into IBrowse.

Right: Easily restart failed downloads with the enhanced download manager.

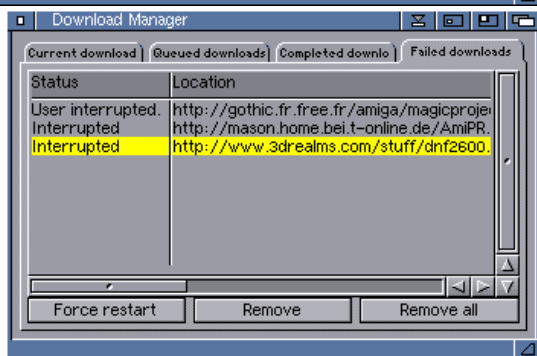

window is now displayed while IBrowse generates the PostScript output eliminating the "has it hung?" feeling you got while printing from IBrowse 2.2. There is still no colour support, and wider pages cannot be scaled within IBrowse to fit on the paper. If you have TurboPrint 7 and install Ghostscript, you can send IBrowse's PostScript to a non-PostScript printer, albeit in black-and-white. A workaround (detailed in Clubbed issue 8's Top Tips) is available to scale the PostScript output to better fit on A4 pages. With TurboPrint and the workaround in place, PostScript printing does give excellent results using smooth scalable fonts; however, it is a bit of a kludge.

Documentation

At the time of this writing, IBrowse 2.3 is supplied with only the basic documentation prepared by HiSoft for IBrowse 2.0 several years ago. Extensive new documentation is being worked on that, we understand, covers not only the operation of the program but also more

complex matters like setting up PostScript printing via Ghostscript.

Conclusion

In version 2.3 the IBrowse team has clearly concentrated on improving the number of web pages it works with, which is clearly the most important aspect of a browser. The interface has seen only minor enhancements, but as it has always been an IBrowse strong point, the work was definitely put into the right places. The improved support for JavaScript and SSL has made accessible many sites that were previously denied to IBrowse users. Other smaller improvements, such as those to tabbed browsing and the download manager, make the new version a joy to use. From some informal testing IBrowse now seems to be the most universally compatible Amiga browser, and in my opinion it is also the most comfortable to use. Altogether IBrowse 2.3 is a fine browser now and seems to have a bright future ahead.

Results

Pros

- + Improved page compatibility.
- + Excellent interface.
- + Built-in SSL.

Cons

- No CSS support.
- No plug-ins.
- Limited docs.

Pretty Good!

TOTAL AMIGA

Kicksoft

If you don't see what you want, just ask!
Our range is always growing!

Graphics

Drawstudio

This excellent Graphics package available one again!! Comes on CD and includes **Texture Studio & Image Studio**.
£35.00

Photogenics 5

This excellent Graphics package by Paul Nolan. Comes on CD.
£70.00

Image Engineer

Great Image manipulation program. Add effects to images such as Jigsaw.
£25.00

Candy Factory Pro

Create 3D Text from any standard font and use them on web pages etc.
£35.00

Art Effect 4

Billed as "Photoshop® on the Amiga". Excellent graphic package. Comes on CD.
£39.99

FxPaint

With over 70 effects this is a superb addition to any software collection.
£60.00

Image FX4

THE image manipulation package !! 100s of effects.
£99.00

Players

Moovid PPC

PPC version with both WARPUP and POWERUP versions. Comes on CD
£18.00

Moovid

Play AVI, Mov and QT files on your Amiga®. Comes on CD.
£12.00

Frogger PPC

PPC MPEG player. Comes on CD with example MPEGs.
£18.00

Frogger

68k MPEG player. Comes on CD with example MPEGs.
£12.00

Riva

The fastest 68k MPEG player on the Amiga! Comes on CD with MPEGs.
£9.00

SoftCinema

PPC AVI, QT and Mov player. On CD with example Movies.
£9.00

AMP 2

PPC Mpeg, CD-i and DVD player. The only way to play DVDs on the AMIGA.
£18.00

Internet

Inet Dial

Home server on your Amiga®, includes Apache and Geek Gadgets.
£40.00

AWeb Upgrade

Excellent web Browser. Upgrade from OS 3.5 or OS 3.9. Comes on Floppy.
£30.00

Games

NEW

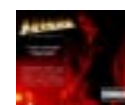

PayBack

£35.00

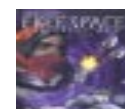

Freespace

£35.00

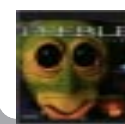

The Feeble Files

£35.00

Misc

TaskiSMS

Send Text Messages to mobile phones from your Amiga! Comes on CD.
£12.00

FxScan

The only Scanner software that offers OCR on the Amiga today!!
£30.00

OS 3.9

Latest operating system for the Amiga. Comes on CD.
£30.00

Aminet

Latest Aminet disk or the latest series. Gigabytes of Amiga Software.
Single £14.99 Series £29.99

VHI STUDIO

Connect digital Cameras to your Amiga and so much more
£30.00

Amiga Forever 5

Emulate a AGA based amiga on your PC.
Full Version £40.00 Upgrade £25.00

Utilities

PFS 3

The fastest and safest file system available, up to 300 times faster than FFS.
£35.00

Metaview

The best Clipart viewer on the Amiga®. Comes on CD with clip art images.
£18.00

Diavolo

The best backup program on the Amiga®. Comes on Floppy disk.
£50.00

PhotoFolio V2

The professional way to view, catalogue and manipulate your images.
£30.00

GoldEd

The best Editor, Program Editor, HTML Generator on the Amiga.
£30.00

Turboprint 7.21

Use modern printers with 24 bit output!! The quality is astounding.
Full £40.00 Upgrade £25.00

Make CD (DAO version)

CD writing software. Compatible with most CD writers/rewriters.
£50.00

Spitfire 2

If you have a 3com Palm® or compatible then you need this program! Comes on CD.
£25.00

Mediapoint

multimedia presentation tool on your Amiga.
£40.00



www.kicksoft.co.uk

Add £1.00 UK postage per item. Make cheques payable to **Kicksoft Ltd.**

We accept Solo, Switch, Mastercard & Visa

Kicksoft Ltd.,
30 Whitegate Way,
Tadworth,
Surrey, KT20 5NS
Tel/Fax (01737) 219280
sales@kicksoft.co.uk

.info

Developer & Distributor
IOSpirit
http://www.iospirit.com

Price
Full..... 74.99E (£52)
1.x Upgrade.... 48.99E (£34)

Requirements
AmigaOS 3.0
or MorphOS
10Mb free RAM
10Mb Hard disk space

Test Systems
Amithlon
AMD Athlon XP 2000+
256Mb RAM
AmigaOS 3.9

A1200
Blizzard PPC 060/603e
240Mhz
128Mb RAM
AmigaOS 3.9

Supplied by
IOSpirit

Use "color variations" to quickly adjust an image to the perfect colour balance.



fxPaint 2

IOSpirit are one of the most active Amiga developers of recent years. Robert Williams take a look at the new version of their flagship image processor.

We last looked at fxPaint way back in Clubbed issue 5, so I'll start with a reminder of what the package is all about before I dive into the new features of version 2. At the core of fxPaint is a paint-on, paint-off image processing system similar to Photogenics version 2. With this system you paint onto an invisible "drawing layer" over the image itself. You can paint using a variety of tools such as freehand, lines, boxes, and ellipses. Rather than just being able to apply colours, you can also paint using a wide range of different image processing effects. For example, you could paint a blur effect over a small region of the image. Because the painting is happening on a separate layer, you have much more flexibility than with a normal paint program. What you have painted is not committed until you click the "Fix" button in the toolbar. If you make a mistake, you can rub it off by painting with the right mouse button. If you wish, you

can change the effect, its parameters, or the paint colour at any time and the results will instantly be shown. When you're happy with the results and want to move onto a different effect or colour, just click "Fix" and your changes are committed to the image. Unlike ImageFX 3+, ArtEffect, and Photogenics 4+, fxPaint has only one drawing layer; you cannot go back and edit a fixed layer later.

Brushes

When you're painting freehand, the selected brush controls what is put down by each click. fxPaint has a brush manager that shows a thumbnail of each available brush. They can also be selected from a pop-out list in the toolbar. Several brushes are predefined. Custom brushes can be imported from any open image, and the brush creator can be used to make brushes, emulating various real-world media (pencil, chalk, pen, etc.). The brush creator is fairly limited; the biggest brush you can make is 30 pixels wide, and the only other option is the density. It's a pity that the ability to modify the size, density, and type of brush on-the-fly over a wider range of values wasn't added to version 2.

Effects

fxPaint has a range of special effects that can be applied to the drawing layer. This means you can either paint them onto a specific area of the image using any of the painting tools or apply them to the whole image. The "Effects Manager" window holds a list of all the available effects that are split into categories based on the results they create. The available effects range from useful tools such as blurs and colour corrections through fun effects that create eye-catching results such as "ExploTile" and "Supernova."

For version 2 a number of new effects have been added, and

some existing effects have been reworked and improved. "Antialias" subtly reduces "jaggies" in sharp edges. This is effective but has no options; it would have been nice to be able to control the intensity. "Glow" adds a glow of the current colour to the bright areas of the image, creating an interesting effect. "Ripple" creates even or uneven distortions in lines across the image, but it lacks a direction control. "Whirl" and "Pinch" distort the image at a point that can be selected by clicking on the image in "position mode." The size and power of the pinch or the angle of the whirl can be adjusted. Of the improved effects, the ones that stand out are "Fish Eye," which now sports a position mode and more controls over its look; the "Pyro"

"some effects really have too few options to be useful"

plug-in, which gives more realistic results as it "burns through" to white; and the bump mapper, which is much faster and produces a more attractive result.

Despite the overall improvements to the effects and the way they are handled, a few minor annoyances remain. Some effects really have too few options to be useful on most occasions. For example, the motion blur only blurs in one direction: from right to left; you can't change it to any other angle. However, as some of the effects such as "FishEye" have been improved with many more options, hopefully the limited effects will be given more flexibility in a future upgrade.

Colour Variations

If you're looking for a quick way to improve the look of a scanned image of digital photograph, then you may find fxPaint's new "Colour Variations" window handy. This window shows the

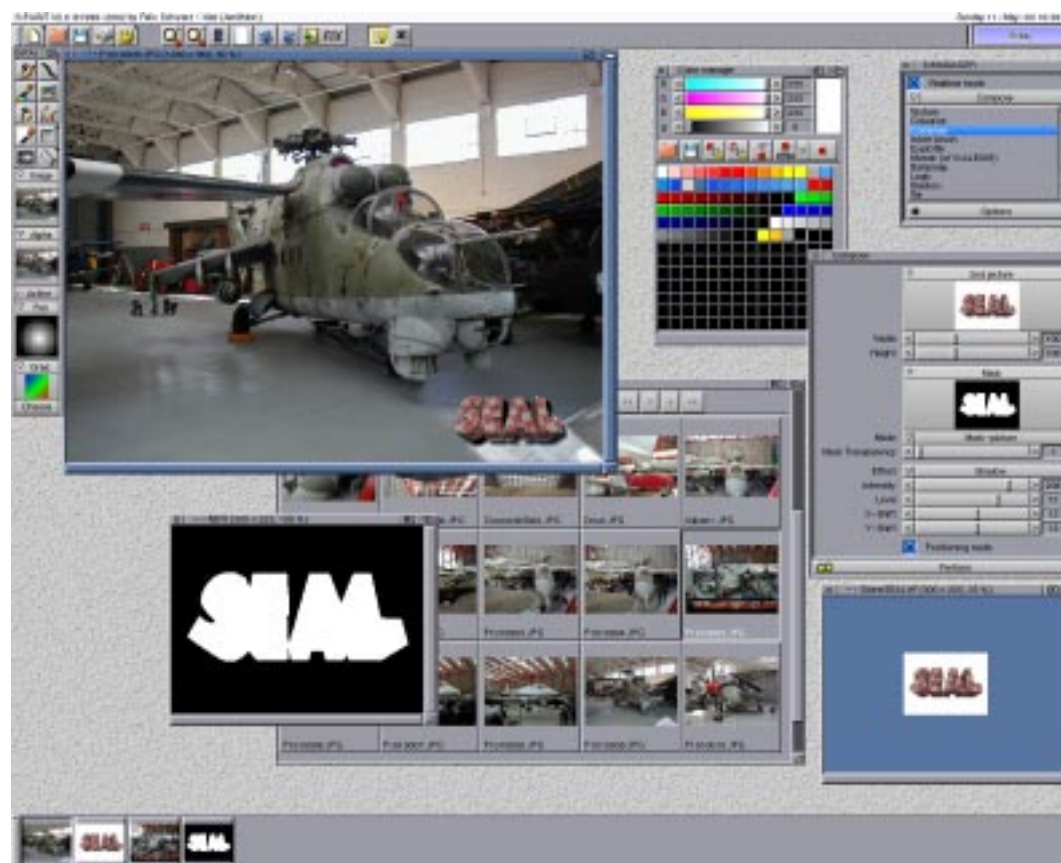

original image with a set of thumbnails, each showing the result of a different operation. These include increasing brightness, contrast, and gamma, as well as an option to add or reduce the three colour channels. To preview the operation, you just click the appropriate thumbnail. The result is then used as the basis for all the operation thumbnails so that you can build up several operations within the "Colour Variations" window. At all times the original image is shown in its own thumbnail for comparison. Clicking on the original removes any processing you have added. When you're happy with the look, the "Perform" button carries out all the processing on the original image. Unfortunately, this procedure cannot be undone.

Progress

A major improvement over previous versions of fxPaint is the improved progress reporting in version 2. At the right-hand side of the tool bar is a progress gauge that shows how much of the current operation has completed. In earlier versions, this bar seemed to jump from 0% to 100% without reporting progress in between for most effects. This is doubly important because fxPaint doesn't show

you the effect on the image until it has finished processing. Now, in most cases, the progress bar works properly and allows you to see an effect's progress. Having a progress bar that works is a great bonus, but there are a few effects in which the progress bar has to fill up several times before they are complete, somewhat negating its usefulness. I'm also pleased to see that fxPaint now

"fxPaint offers a number of special tools to make your life a bit easier."

displays a wait pointer while it is busy, while processing an effect, for example. This simple addition eliminates the uncomfortable feeling that I often had, when using previous versions, of not knowing whether the program is working or if it there is a problem. Although neither of these enhancements amount to a new feature, they do make fxPaint 2 much more comfortable to use.

Gradients

In addition to the standard palette window, fxPaint now boasts a powerful colour gradient feature. Several examples are supplied, and custom gradients can be defined in the "Gradient Manager" window. An unlimited number of colour transitions can

be added to each gradient. These transitions are created by adding colour points that are displayed below a preview of the resulting gradient. The points can be dragged into position, allowing you to make gentle fades or sharp transitions between colours. Gradients can also have transparent sections. Unlike with other programs I have used, transparency is

independent from the colour points. For example, you could have a gradient with a sharp colour change in the middle but a gradual fade. This effect is achieved by having separate transparency control points along the top of the preview. You can set the transparency of each point, and fxPaint interpolates smoothly between them.

Once a gradient is defined, you can switch to gradient drawing mode by clicking on the confusingly-named "Choose" button in the toolbar. The gradient in use is then selected by a pop-out list that is also in the toolbar. Then, if you paint with a brush or the special gradient tools, the selected gradient colours are used to fill your painting. The gradient mode

Using the "compose" effect to add a logo to an image. Notice the fxAlbum window with the thumbnails in the background.

works in an interesting way. Instead of treating each object you paint separately, filling it with a gradient, fxPaint looks at everything you've painted before fixing and applies the gradient to the whole thing. This means you can create complex shapes and have them filled by the gradient. Adjusting the gradient colours or transparency in the manager window causes any painted gradients that haven't been fixed to change in real time. With this feature you can get the result you want very easily. There is also a new gradient effect that tints the current image with the selected gradient. This is a handy tool and produces an effect that is difficult to achieve in other ways.

Web

Whether you're a web designer or just want to throw together a simple home page, fxPaint offers a number of special tools to make your life a bit easier. Earlier versions had the image map feature for making client-side image maps (clickable hot-spots in images). This feature is still included, and version 2 adds a tool called "Navigation Builder." This tool is designed to make a series of button images that highlight as the mouse pointer moves over them. To start off with you need an image with one row or column of buttons. The buttons can be page titles, icons, or whatever else you'd like, and they can be on any sort of background. Then you make a duplicate of this image, using the clone function, and add the buttons in their highlighted states. The only consideration is that the background must remain the same. Then run Navigation Builder, select your images, and tell it whether the buttons are in a column or row. Based on the differences between the images, fxPaint will work out where the buttons are and cut them out of the image and create the required HTML and JavaScript code. All you then need to do is

to paste the code into your page and edit the links so that they point to the pages on your own site. This is a very handy feature that automates an otherwise tedious job.

fxAlbum

When you've got thousands of images on your hard drive or CD-ROMs, just finding the image you want can be a major task. Step forward, fxAlbum - a handy thumbnail generator that will create a catalogue of all the images contained in a directory and its subdirectories. The size of the thumbnails is defined in the main preferences window. The images can be sorted by their filenames, and the order can be rearranged using drag and drop. When the thumbnails have been created, the album can be saved so it doesn't have to be generated each time and so you can view the album when the original pictures are not available. The second option is useful for CD-ROMs; you can

"The HTML album feature is well thought-out and comprehensive..."

check if an image is on a particular disc without inserting it in the drive. Double-clicking on a thumbnail loads the picture into fxPaint for editing. A new "Album Tools" window contains options to rotate the image (excellent for digital camera shots) and to add a comment. The tools window is particularly nicely implemented: after entering a comment and pressing Return, it moves on to the next picture so you don't have to keep opening and closing the window. Albums can be printed as a series of thumbnails for a permanent reference, and fxAlbum can automatically generate a gallery of HTML pages for upload to a website.

The "HTML Export" function of fxAlbum has been significantly enhanced in version 2 and now offers many more options. The basic idea is that it creates an HTML page displaying your thumbnails, which are then linked to the full-size images. The overall look of the resulting web pages can be customised by choosing a skin; several examples are supplied. The skin controls the layout of the pages, any background colours, or pictures, and it can add a border

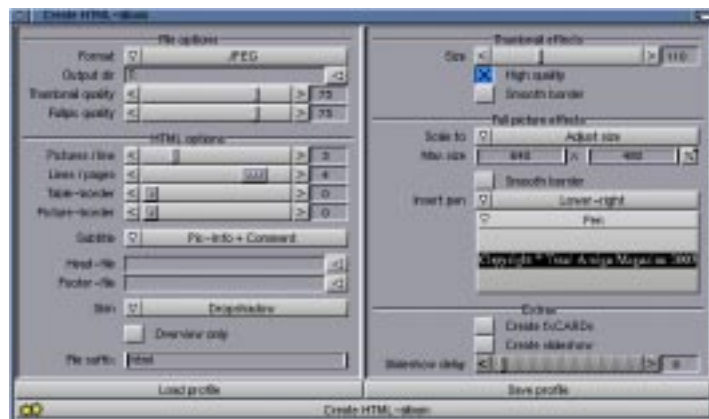

Customise the HTML album to your hearts content.

around each image. The documentation includes details of the skin format so you can make a skin to match your website. The "Create HTML-album" window has many options, so you can customise the HTML output exactly to your liking. The number of thumbnails on each page and their sizes can be defined, and you can have a slightly embossed border applied automatically. Each full-size picture, linked from its thumbnail,

is presented on a separate page with "Next" and "Previous" links for easy browsing. You can choose to have the originals automatically scaled down by a percentage or to a set size suitable for web viewing. FxPaint can automatically add any brush to each picture. A good use for this feature is to add a copyright statement to the full-size images. It is even possible to add the option of sending an image as an e-mail "postcard" from your pages; however, this requires you to load a PHP4 script onto your web server. Overall, the HTML album feature is well thought out and comprehensive. Anyone with a digital camera and a website is sure to find it useful.

fxConv

fxConv is a quick way of converting a directory full of files into a different file format. New features in version 2 allow it to perform some image processing operations as the files are converted. Options in the fxConv window let you specify a percentage scaling for the images and allow them to be rotated a user-defined number of degrees. More powerful effects can be applied by selecting an

ARexx script to be run on each image. Example scripts, which add various borders to the images, are supplied.

Interface Improvements

A number of enhancements have been made to fxPaint's interface to make the program easier to use. A new "Painttool Settings" window shows the options for the currently selected painting tool (line, box, fill, etc.) and can be left open as you work. The "Size Manager" allows you to define custom resolutions that can then be used where an image size is required when starting a new blank image or resizing an existing one. The undo system has been rewritten so that you can now undo fixations - a big improvement over version 1. This area could still be further improved because there are still a number of operations, such as colour variations and resizing, that cannot be undone.

Need for Speed

Regardless of the platform on which you plan to run fxPAINT, IOSpirit have provided optimised support. There are versions for every 68k series processor from 68000 to 68060 with FPU. PowerPC accelerators are supported under both PowerUP and WarpUP, and there are also native modules for MorphOS and Amithlon. IOSpirit also state that they will support OS 4 when it is

Results

Pros

- + Improved performance.
- + Excellent extras.
- + Powerful gradients.

Cons

- Basic image processing engine.
- Limited brushes.

Pretty Good!

released. In our review of fxPaint 1.0 we were disappointed with the performance of many effects on 68k and PPC systems. I'm pleased to report that these issues largely seem to have been resolved. Most of the effects are now faster, and the whole program feels much slicker on a 68k system. In our tests, adding a PowerPC accelerator didn't make quite the difference in performance we expected. Intensive effects were two to three times faster on a 603e 240Mhz compared to the '060 50Mhz on the same board. On Amithlon the performance was stellar - my Athlon 2000+-based test system performed the same effects about ten times faster than the PPC-based Amiga. All that said, fxPaint proved very usable on all our test systems, but, in common with most image processors, there are a few effects for which you will have to wait a while on a 68k-based system.

Conclusion

fxPaint is a very useful program with a wide range of features many of that are very good alone. However, when the image processing side is put up against the likes of Photogenics and ImageFX, its lack of a powerful layers engine and brush handling is definitely a disadvantage. With those deficiencies at its core, fxPaint never feels quite the sum of its parts. That said, the interface and usability enhancements make version 2 much more comfortable to use than version 1. So if you're looking for a simple image processor that is easy to use and well documented with handy extra features such as fxAlbum and the navigation builder, then you're likely to be very happy with fxPaint. My advice would be to download the demo and see how it suits you.

Aqua

Mick Sutton dives into a this point and click adventure from Emerald Imaging.

Aqua is a point and click adventure which takes you on a journey of discovery to the bottom of the ocean where a whole world of surreal locations and mind bending puzzles awaits you! The game is played from a first person perspective (what you see on screen is what your character sees) and each screen is pre-rendered. Anyone who has played Myst will be instantly familiar with this game, it has a very similar style, which is not necessarily a bad thing because Myst was one of the best selling games ever.

Getting Seaworthy

The game can be played directly from the CD, if you want to install it on your hard disk all that is required is to copy the contents of the CD into a new directory and name it Aqua. In the amigaguide documentation it states about 200 Mb of disk space is required. Four different game icons allow you to run the game configured for your system, the choices being AGA, RTG if you have a graphics card, AHI_AGA for those with a sound card (or if you prefer to use Paula via AHI) and AHI_RTG if you are lucky enough to have both a graphics card and a sound card. The fact that Aqua

supports graphics and sound cards should mean that it is compatible with emulations that don't include the AGA chipset such as Amithlon. Before running Aqua for the first time you need to set the screenmodes required by double clicking on the screenmode icon. You need to select a mode for the main game screen which is 640x400 resolution and a mode for the cinematic cut scenes which are 320x200. These are NTSC resolutions so if you do not have an exact match use the closest larger screenmode you have.

Let's Dive In

On starting the game you are given the option to start a new game or load a previously saved game. If you start a new game you are treated to a short animated sequence introducing you to the story of the game. This starts with an oil rig that sinks during a storm and as an intrepid adventurer you decide to hire a research sub and go in search of valuable salvage.

As we said earlier Aqua is very much in the Myst mould. The game presents itself as a static scene which you have to interact with, you have options to move forward, backwards and turn left or right and of course pick up objects and use them either right away or later on in the game.

The whole story starts off with you at the quay side looking at a moored submarine. You get into

the submarine and explore the depths in search of clues as to what made the oil rig vanish beneath the waves. It is at this point (whilst guiding the submarine) that you realise that it's not all static scenery, because as your vessel moves underwater you see through the pilot's screen the sea bed passing you by. OK now it's time to engage your brain as there are many puzzles for you to solve to move forward in the game, the first being able to understand what the whales are singing about! Yes you did read that right, it is important to note that sound is essential to the game, in this part to identify which songs the whales are singing (once you find them using other clues found on-board the submarine) to guide you to a secret entrance on the sea bed to a whole new world.

The game carries on in this style, move to a new beautifully rendered scene, look and listen for clues and interact with objects and beings to make your way your way through to the next. I must say I am not the biggest fan of this genre of game (no explosions, blood or mayhem) but for some reason I felt compelled to carry on, I think it is that you don't want to be beaten by the puzzles, which are quite well thought out and vary in complexity (increasingly harder as you progress through the game). The scenery does vary a fair bit, you are not stuck in a

submarine (claustrophobic for some maybe) for long and will be discovering many different locations as you explore the new world you have found (you did listen to what the whales were singing to you... didn't you)?

The scenes are 8 bit graphics but I found when I selected a 16 bit screenmode for both the game and cinematic scenes I didn't get a glimpse of a corrupted scene and delays when switching from one to the other. There are one or two little annoying things I found in the game, for instance you only have 3 saved games available to you and they cannot be renamed, which could help prompt you as to what stage of the game you were in when you saved them. This is quite annoying as I found I had to load a game 3 times before I found the "save" I was looking for (or maybe my memory is just not it used to be). Another minor niggle is the quality of the cinematic cut scenes which I thought were pretty poor, not essential to the game-play but give a rough edge to what is otherwise quite a well polished game.

Sink or Swim?

All in all I found this a rather pleasant game that turned out to be more enjoyable than I thought it would be. It's got nicely drawn and interesting scenery, in-game animations and sound to boot! The puzzles are very well thought out and will get your brain in gear, just don't expect to be able to release pent-up energy in the way you can with say Quake II or Slam Tilt!

Result

Pretty Good!



.info

Developer
Emerald Imaging
<http://www.telusplanet.net/public/samel/>
Demo version available.

Available from
Fore-matt Home Computing
www.forematt.co.uk
+44 (0) 8700 112234

Price
\$14.95 (from developer)
£10.00 (from Fore-matt)



Subway USB

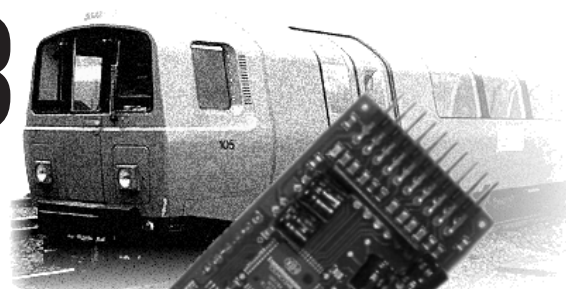

If you've been looking eviously at Zorro and PCI USB cards but have an A1200 without a slot to put one in then Jonathan Haddock might just have something to interest you.

The Subway is a USB controller card that connects to the clockport and has an integrated four port hub (i.e. four USB ports are present on the card). Unlike the Spider, Elbox's PCI alternative for their Mediator bus boards, the Subway does not have an internal port. This, however, was not a problem for me.

The Subway supports USB 1.1 and 2.0 but not version 2's highspeed mode; this means USB 2.0 devices will work (providing the drivers support them) but only at a maximum of 1.2 megabits per second. Like the Spider and the Highway, the USB Stack (the software that allows the USB ports to be used) is Poseidon written by Chris Hodges (cheers Chris!). Poseidon is controlled by the Trident preferences program. Poseidon supports most Human Interface Devices (HIDs), card readers, memory sticks, and some printers and scanners. There is provision for the use of a "pencam" for which the driver is provided. For more information on Poseidon you could refer to the review of the Highway in Total Amiga issue 12.

Installation

The Subway, whilst a good USB card in my opinion, was not all

that easy to get working. I had a few problems which I will explain later. Anyway, installing the hardware is relatively easy; having unpacked your Subway (and preferably read the instruction manual) you will need to take the case and any busboard you have installed off your Amiga to gain access to the clock port (the set of pins about central on the motherboard, by the RAM chips). Then take the thin grey cable supplied with the Subway and connect it to the clock port so that the red stripe is at pin one of the clock port (the left hand side). The next part was tricky because I didn't find the documentation very clear; you must plug the other end of the cable into the Subway, in this case pin 1 is easiest found by turning the subway over and looking for the arrow, indicating pin one, printed on the circuit board. The diagram below shows this clearly (but please note the diagram is not to scale!).

Having connected the Subway to the Amiga you must connect the USB ports to the other end (this I found relatively easy). Two blanking plates are supplied to fit the back of a tower with two USB ports on each plate. Taking the plug on the end of the grey cable (attached to the ports) plug it into the USB port connector pins so that the black wires are at the top as you look at the back of the Subway (see picture). The USB connector you can see in my picture is likely to be different to yours as mine it is a third party connector. For the supplied connectors the black wires should still be at the top, you'll just have two of them!

Software Installation

I then booted my Amiga and attempted to install the software but the installer helpfully decided to unmount all of my partitions, hmm. This hopefully won't happen to you but if it does boot without startup-sequence, run setpatch and then the installer should work. Then reboot and in

theory your subway should be ready for use. If your Amiga won't boot it is likely to be a problem with the startup sequence so edit it to comment out all unnecessary operations. Sorted! (I thought I should mention that we have installed Poseidon on several Amigas without experiencing these problems, Ed.)

Occasionally I boot the Amiga and am presented with an error message that tells me that the subway device could not be loaded; this is usually sorted with a reboot and the USB devices become usable. Failing this a complete power off and back on again fixes the problem.

Compatibility

I have tested the Subway with a memory stick, keyboard (with hub) and mouse. Firstly, the memory stick was mounted successfully and appeared on the Workbench. It was readable and writable and was unmounted upon the removal of the stick.

The keyboard also worked fine but of course is only available for use once the Poseidon stack has loaded. Using the Poseidon HID tutorial (from Total Amiga 14 page 49) to set up some custom buttons and these work fine, even the one button that I set to reboot the machine reboots it faultlessly. The only problems I have with the keyboard is that you cannot hold down a key and expect it to repeat, it won't - you have to keep pressing the key manually. the other is that

sometimes the keyboard refuses to type and so must be unplugged and reconnected (this is OK even if the Amiga is turned on).

The mouse on the other hand does have one problem, IBrowse 2.2 (IB hereafter). The mouse I am using does not seem to like activating hyperlinks in IB. I have checked using AWeb and the problem only seems to lie within IB. (this may be caused by not running the new input.device supplied with Poseidon, Ed.) The mouse did, however, worked quite well with Quake.

Conclusion

Personally, I think the Subway is a very good card and is easily worth the money. It avoids the ethical issues with Elbox's drivers and would still leave Mediator users with a spare slot (which was the reason I bought the Subway as I wanted a slot free for my TV card). Although there is no high speed mode I have no peripherals that require this extra speed. I would highly recommend this card.

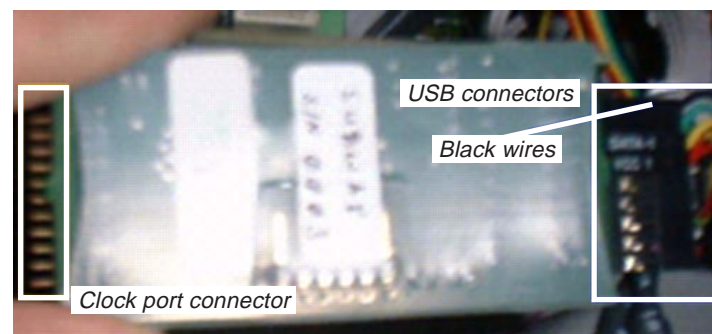

Canada, this is YOUR source for current Amiga products!!



Special on NEW in-stock items (while they last):

AmigaOne Motherboard wih 256 Meg RAM ~ \$999 CDN / \$715 USD

Catweasel MK3 PCI/Flipper ~ \$145 CDN / \$105 US

X-Surf2 Network cards ~ \$145 CDN / \$105 US

Quake2 ~ \$55 CDN / \$40 US

Amithlon ~ 190 CDN / \$140 US

Total Amiga Magazine ~ \$15 CDN / \$12 US (includes N. America surface shipping)

Check our website for excellent prices on:

AmigaOne Systems & Boards

Elbox Towers

Mediator PCI busboards

USB & IDE Controllers

3.1 ROMs

OS 3.9 CD

Software

etc.

The only "early bird" AmigaOne retailer in Canada!

<http://www.livewiresystems.ca>

email: amiga@livewiresystems.ca

Ottawa, Ontario, Canada

.info

Developer
E3B
www.e3b.de

Available from
Forematt Home Computing
www.forematt.co.uk
+44 (0) 8700 112234

Price
£70.00

PD Paradise

AmiNetRadio

Developer: Matthias "UltraGelb" Böcker **License:** Freeware **From:** <http://anr.amigazeux.net>
Requirements: '040/40Mhz+, 4Mb free fast RAM, AmigaOS 3.0+ or MorphOS, MUI 3.8, Internet connection.

Do you like the idea of listening to radio stations from across the world, for free, with the help of just your Amiga and an Internet connection? Well, then, you're reading the right review. AmiNetRadio (that's Amiga Network Radio, by the way; it has nothing to do with Aminet) is a native Amiga player for Shoutcast streams. These streams are MP3 encoded audio data that are available from servers at radio stations around the world. Some of these are "real" stations that also broadcast over the air to their local populations, and many others only broadcast over the Internet. The Amiga has had several Shoutcast players in the past, but although they were effective, they had very few features to manage your stations or to make listening more pleasurable. The team at #AmigaZeux already have several great products under their belts, including AmiTradeCenter (an FTP client) and dynAMlTe (an online bomber-man game). With AmiNetRadio they have taken a similar approach to those earlier productions: start with a simple idea and take it to the max! They do this by including a huge range of useful features and some impressive eye candy.

When you start AmiNetRadio (ANR), a small window appears with a number of buttons,



The Zoom visualisation plug-in supplied with ANR. You can also use plug-ins developed for AmigaAMP and AMPlifier.

including basic playing controls at the bottom and several lines of information at the top. Instead of standard gadgets, ANR has a "skinned" interface. This means that while the functions remain in the same place, the look of all the program windows, including the buttons and display colours, can be changed by selecting a new skin. While the interface looks great, many of the buttons are very small, especially when running on a high resolution graphics card screen. It would be nice to see an alternative, larger layout in a future version with new skins.

To start listening to a Shoutcast stream you don't need to search using a web browser or even leave ANR. Clicking on the lightning bolt icon brings up the shout search window. Streams are grouped by genre (pop, rock, classic, talk, etc.), and each stream has a description and shows the name of the song currently being played. You can search for either a specific genre or a particular word or phrase in the description and current song title. ANR also allows you to limit your search to a range of bit rates (which indicate the quality of the stream and the speed of Internet connection required), and you can set the number of results to be returned. A list of matching streams is then retrieved from the Shoutcast server; then you can start listening to a stream simply by double-clicking on it. Some stations have several servers in a "cluster" to serve a larger number of listeners. ANR supports clusters and will try each server in turn until it makes a connection.

As a stream plays, the name of the station and a slogan that station may have set is displayed in the top line of the ANR window. Below that is the song title and the station's genre. You can double-click on the station name to open its website. (This feature uses OpenURL, so it will work with any browser you have



The main ANR window is highly customisable; you can choose the look and which lines of information are shown.

configured.) If you wish, you can customise the information displayed by hiding or showing information lines in the display. You can also show additional information such as details of the track (stereo/mono, play time, bit rate, and frequency) and connection information (data received, data decoded, compression ratio, and CPS). But all that stuff is pretty boring. What is more interesting is the look of ANR's displays. When the text displays change, they have a zooming, blurred effect that looks really cool. You can opt to display a scope graphically displaying the song being played either behind the song title or on a separate line in the window. Right-clicking on the scope icon allows you to choose among five styles in a pop-up menu. These styles range from flashing in time to the music (which looks great behind the text) to a full wave form. In addition, ANR has a separate zoom visualisation plug-in, which is highly configurable and opens in a separate window. If that's not enough for you, ANR also supports visual plug-ins developed for Amplifier and AmigaAMP.

When a stream is playing, the ANR display updates as different songs are played. You can open the "Song History" window to display a list of all the songs and

all the stations you've listened to since you started ANR. Hear something you like? Simply scroll back and find out the artist and song title. When you've found a station you will want to listen to again, you can add it to your playlist by clicking the "Add" button next to the station name in the "Song History" window. While a station is playing, you can click the disk icon in the main window to start saving the stream as an MP3 file. The stream is saved into the directory specified in ANR's preferences, and you can choose an option that automatically saves each song into a new file.

Playing streams across the Internet is not ANR's only function; it can also play your collection of MP3 files stored on a local disk. You can pick a file to play by showing the file/URL string and clicking on the select icon to open a file requester. MP3 files can also be added to a play list or dropped on the ANR window. When playing MP3 files, ANR has the normal controls such as previous and next song, random play, and repeat. The "Playlist" window is quite straightforward. You can add a mixture of URLs and MP3 files to a single playlist if you wish. The list can then be saved either as the default (which is loaded when you start ANR) or under a different name so that you can

have different lists for different moods, styles, or users. URLs can be added to the playlist from the "Song History" window or the search results, or they can be entered into a requester. MP3 files can be added by selecting the files with a standard requester. There is also the option to add the files recursively in multiple directories, but I could not get this option to work.

The preferences window has three tabs – "Players," "Audio," and "GUI" – so you can customise ANR to your tastes. The decoding settings for Shoutcast streams and local MP3 files can be set independently. By reducing the quality you can achieve smoother playback on slower Amigas. For the Shoutcast player you can also set the default directory where streams will be saved when you click the disk icon and set the stream buffer size. This buffer is used to load some of the stream before playing starts so that a temporary slowdown in your Internet connection won't cause a break in the music. ANR uses AHI for its audio output, so on the audio tab you can choose the AHI mode you wish to use. This means ANR is compatible with most add-on sound cards as well as the Amiga's built-in Paula chip. On the "GUI" tab you can select the skin used to texture the ANR interface. A variety of skins is supplied, and since ANR was released, a number of other



The built-in Shoutcast search feature sets AmiNetRadio apart from other streaming audio players.

options have appeared on Aminet. I particularly like "kickass-uproar" skin by catohagen (Aminet, mus/play/ANR-kickass.lha). Also on the "GUI" page are settings for the special effects (you can disable the zooming and blurring if you find them annoying) and options to make window moving and/or dragging opaque. (The windows move when you drag them rather than showing a bounding box, which requires a fast graphics card to look good.)

Before I finish this review, I should remark on ANR's excellent AmigaGuide documentation. This not only explains all the functions of the program but also has an excellent FAQ section. The FAQs cover what you should expect out of your connection and how to get the best performance. The whole documentation has a great sense of humour, which matches the spirit of the program

perfectly. Here is a typical quote from the "Miscellaneous" section of the FAQ:

"Q. ANR is crap! Why don't you use WinAmp or xmms?"

A. Because WinAmp sucks, Windows sucks, xmms sucks, Linux sucks and ANR and Amiga rule. I think that about covers it. => "

Your experience of ANR is probably largely going to depend on the speed of your Amiga and your Internet connection. A good connection with a 56K modem is really the bare minimum to get acceptable streaming audio, but it will be far from even FM quality, and you won't have the bandwidth to do any other Internet activities at the same time. With a broadband connection things will be much better; there are lots of 128K streams that approach CD quality. With a 512K connection you have some headroom for

other concurrent Internet activities. On the processor side of things an '040 is the minimum you'll need for reasonable quality; remember that your Internet connection has to run in the background. ANR uses the MPEGA.library, so if you have a PPC card, you can install the appropriate version (68k, PowerUP and WarpUP flavours are available), and your PPC will be used for decoding. With an '060 or a JIT emulator you should be able to multitask while ANR plays in the background.

AmiNetRadio is an excellent product; the fact that it is freeware and the first release version makes it even more of an achievement. Mathais and the guys at #AmigaZeux have obviously put in a great deal of time and effort getting it right. Having ready access to such a range of stations is fun and a great way to find new music you enjoy. Even with ADSL I did find that many stations could not maintain a continuous stream; however, I think that is likely to be an Internet speed or ISP issue rather than any problem with ANR, as other stations are fine. If you have a good Internet connection and a reasonably spec'ed Amiga, stop reading this and download AmiNetRadio now! If your Amiga or connection is less well-endowed, still give it a try... if it works acceptably, you'll be glad you did.

By Robert Williams

HomeBank

Author: Maxime Doyen **License:** Shareware **Price:** 15Euro (c. £11) **From:** <http://maxworld.free.fr>
Min. Requirements: 68000 CPU, 1Mb free RAM, AmigaOS 2.1, 640x256 8 colour display.

HomeBank is a program designed to help you keep control of your finances. It can be used to record all your monetary transactions, and it gives a constant running total between bank statements. When a statement comes, you can check it against the transactions you've entered to validate them and hopefully spot any errors in the process. In addition to this basic function HomeBank also offers reports so you can see exactly when and where your money is going and a function to monitor the running costs of your car. Let's take a look at some of the features in more depth.

When you start using HomeBank, the first thing to do is to set up your "wallet," which is the program's name for the file

that contains all your account details and other data. Wallet files can be protected with a password, but the files are not encrypted. The next job is to add some accounts to your wallet. You can create as many accounts as you need. For example, you might have a current account, savings account, credit cards, and many more. For each account you can specify the opening balance and a minimum balance so that HomeBank will know whether you are overdrawn. If your account has a cheque book, you can enter the starting cheque number and the program will automatically number cheques as you enter them. Joint accounts with two books are also supported.

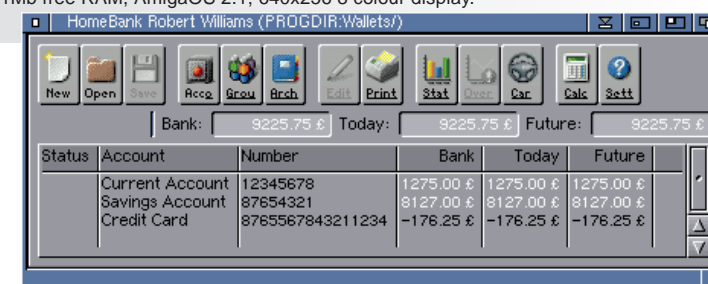

The main window lists all the accounts in your "wallet".

The accounts you define are listed in the main window, and each shows its validated balance (backed by a statement), current balance – including spending after a statement – and future balance, which includes any future commitments you have entered in advance. Above the list are totals showing the same figures totalled for all your accounts. A button bar, with attractive and colourful icons,

along the top of the window gives quick access to common functions. Double-clicking on an account opens a detail window that shows the list of transactions for that account. Like the main window, the detail window has a toolbar of functions at the top. By default (which can be changed) the transactions in an account are listed for the last 30 days. If you want to see a different view, then

Reviews

HomeBank has a powerful set of filters that allow you to display only the transactions you are interested in. For example, you can view transactions that happened between certain dates, specific types of transaction, those with a certain description, or even a combination of the available options.

Clicking on the "Add" button in the account window opens a new window for the details of a new transaction. Here you specify the date, amount, and type (expense or income) of transaction. For each transaction you can select a group to help in later analysis of your income and expenditure. The list of groups is user-defined so you can decide what level of detail you want. For example, you might have groups for rent, car, house maintenance, entertainment, etc.

There are various transaction modes that are represented by icons on the right side of the window. You can choose among credit card, cheque, cash, bank transfer, personal transfer, or none. Some of these modes have special options. For example, if you make a personal transfer, you can specify the destination as one of your other HomeBank accounts. As mentioned previously, a cheque transaction can automatically take the next cheque number. You will probably be using the "Add Transaction" window a great deal, so it is good to see that it is well designed. You can add multiple operations without closing the window by clicking the "Next" button rather than "OK". The date can be nudged forward and backward a day at a time using arrow gadgets, and you can even drop down a mini-calendar to choose dates further in the future or past. These features are also found elsewhere in HomeBank where date entry is required. The window also has keyboard shortcuts for every gadget, and Ctrl+P can be used to pop-up lists on fields like account and group.

If you have regular transactions such as standing orders and direct debits, then you can add them to HomeBank's "Archive" list. Archive transactions can be either added manually from a pick list on the add transaction window or scheduled to be added automatically on a defined

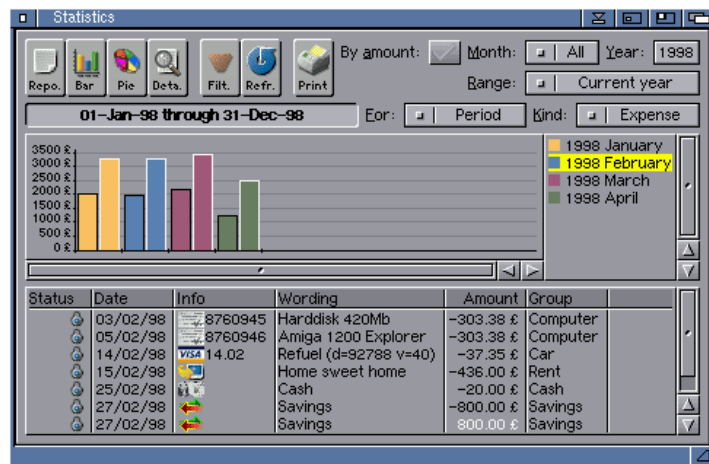

Analyse your out goings and income by month or group using the statistics window.

schedule. The scheduling is quite flexible: you are able to set the starting date and then set the transaction to recur every "n" days, months, weeks, or years. Therefore, you could make an archived transaction that happens every two days or perhaps even every seven years! The archive window always shows the date of the next due transaction so that you can tweak it if you need to.

To use the car running costs feature, you must create a group for each car and use it when you buy fuel. Then on each fuel transaction, you note the current mileage and the number of gallons purchased in the "info" gadget in the add transaction window. This entry has to use the format "d=<milage> v=<gallons>," which seems slightly clunky; it would have been nice to have specific gadgets. A preferences options allows you to switch the units used for the car function from litres and kilometres to gallons and miles. For users in the UK, it would have been useful to have another option for miles and litres, as our fuel is now usually measured in the metric units. When you have completed a few fuel stops and entered their transactions, you can check the "Car" window to see the running costs. You can choose the period of time you want to analyse (so you could easily look at the running cost for the year, for example) and pick the correct car if you have more than one. At the bottom of the window a list of transactions in the car's group is shown, and at the top the fuel consumption and other costs are summarised. Again, unfortunately for UK users, the fuel consumption is shown using

the continental system, litres per 100 kilometres (or gallons per 100 miles if you choose that option) and not miles per gallon. Despite those quirks it's still a good way to monitor your car's running costs, and if you're using HomeBank anyway, there's little extra effort in using the "Car" feature.

With a few months worth of transactions in HomeBank, you can start to use the statistics features to analyse your income and expenditures. There are two statistics windows: "Overdrawn," which monitors your account balance, and "Statistics," which allows you to break down your spending and income by group of time. The "Overdrawn" window has a line graph showing the balance of the selected account over time; you can select the time period to display. A red line along the X axis shows the value at which you are overdrawn based on the minimum you entered for this account. The line allows you to see the trend in you balance and which parts of the period are especially bad. Clicking at a point along the line pops up a bubble displaying the details of that transaction. Also available is a report view that shows a list of transactions, their values, and the overall balance. "Prev" and "Next" buttons allow you to jump quickly to overdrawn transactions in the report view.

The "Statistics" window can summarise your transactions – again, in a specified period – by either group (rent, car, entertainment, or whichever groups you have defined) or month. Unlike the "Overdrawn" window, "Statistics" displays information for all your accounts at once so you can see when transfers have been made. The

results can be displayed as a report list, a bar chart, or a pie chart. With a chart displayed you can click on a pie slice or bar to get a bubble with its value. It is also possible to open a data view below the chart. If you then click on one of the entries in the key, all the transactions that make up that entry will be displayed. Therefore, if you think, "Wow, I didn't remember spending so much on my Amiga this year!" you can quickly see that Total Amiga subscription making a dent in your savings!

Most HomeBank windows have a print option. While this is a useful option, it isn't too much to get excited about. In all cases HomeBank prints by sending a text dump of the current list to your printer. This does not include any graphics (it's not possible to print charts, for example) or special formatting. That said, it is perfectly adequate for records, and the printouts include the print date and any filter criteria so you know exactly what is included when you look back at the printout later.

In these days of Internet banking it is worth noting that HomeBank is not able to import files intended for other programs or bank statements in electronic format. It does have the facility to import transactions from a CSV (comma separated values) formatted text file, but it needs to be in the correct format. Of course, with a bit of work and a short AREXX script, it might be possible to reformat a downloaded statement into a suitable format for import.

Overall I found HomeBank to be an excellent product. It has been in development since 1995, which shows in the way its interface is really slick. Common repetitive operations such as adding a transaction or validating against a bank statement have been made as easy as possible. The "Car" feature is not quite so polished (especially for those of us in the UK), but is still useful. The powerful filtering, sorting, and reporting features allow you to get an overview of and spot trends in your finances quickly, which should be very helpful. You might even find it saves you the £11 shareware fee!

By Robert Williams

Kicksoft

If you don't see what you want, just ask!
Our range is always growing!

Amiga Forever 5

Up to 30 times faster!



Fast Amiga Emulator and Connectivity Package for Windows

- Fast JIT emulation, up to 30 times faster than previous versions of Amiga Forever.
- Amiga runs in a window or in full screen mode.
- Amiga Explorer for Amiga connectivity.
- Fully licensed Picasso96 software.
- All Amiga ROMs up to version 3.1.
- Includes: Personal Paint 7.1b Directory Opus 5.5 (courtesy of GPSSoftware), TurboText
- MPEG-1 videos: The Deathbed Vigil and Jay Miner Speech included on the CD.
- Plus much more.

Version 5 Upgrade from V. 4
£40.00 **£25.00**

Introducing... PageStream 4.1!

Quark wishes... PageStream features!

PageStream 4.1

The Premier DTP program on the Amiga. Mac & PC version also available.
£199.00

PageStream Upgrade

From pagestream 2.xx to 4.1 **£95**
From pagestream 3.xx to 4.1 **£79**
From Pagestream 4 to 4.1 **£39**

Cross upgrade

Upgrade from Amiga version 4.0. to PC or Mac version.
£89.00

PageStream Extras



Warp and bend any text into any shape you want !!

Text effect 2 £50.00



Complete collection of 120 scalable borders

Basic & Geo Borders £55.00



www.kicksoft.co.uk
Add £1.00 UK postage per item. Make cheques payable to Kicksoft Ltd.
We accept Solo, Switch, Mastercard & Visa

Kicksoft Ltd.,
30 Whitegate Way,
Tadworth,
Surrey, KT20 5NS
Tel/Fax (01737) 219280
sales@kicksoft.co.uk

Support Tales of Tamar

... UPDATE ... UPDATE ... UPDATE ... UPDATE ...

Sam Byford finds out that there's nothing like a good war to spice things up in the world of Tamar. Find out all the latest news on this play-by-email strategy game.

And so to the third chapter in the Tales of Tamar. V0.48 introduced rebellions and other updates which mean Tamar now has Dragons and a change to the annexation rules. Expanding your realm is a necessity if you hope to survive and, as I mentioned in the last magazine, taking an Over-Lord is one way to do this. Another way is to just take the land you need whether it is unoccupied land or someone else's you want to steal. Whatever the method there is one thing you need and that is an Army.

Setting up an army is easy enough, go to the army screen once you have built an army camp, increase the percentage of the population you can recruit to be fighters then make your army (this must be above 50 men, once an army drops below 50 it will disband!) and give it a name. For your armies to be able to fight they need weapons, and armour is helpful if you don't want them to be killed off by the local farmers and their pitchforks (or worse, another army!)

Weapon Statistics

Weapons and Armour are not all that prevalent at the start of your game but if you have been playing Tales since I started these updates then you should have enough money to buy some from your blacksmiths or the market. Each item of weaponry falls into one of four categories: one handed; two handed; projectile; or artillery. Some types of army are restricted in the sorts of weapons they can use, for example infantry cannot use lances. Each weapon has two sets of figures - distance and damage.

With one and two handed weapons the distance will always show as #/0/0 (In this paragraph "#" represents a number from 1 to 25) and projectile or ballistic weapons will have #/#/#. This stands for short-range/medium-range/long-range and the higher the

Choose from a wide range of weapons to equip your new army.



Introduction

Tales of Tamar is a turn based strategy game which is played on-line via EMail (although the workings are hidden by a beautiful hand-drawn interface). For full details take a look at Sam's review in Total Amiga issue 13 or visit the game's web site at www.tamar.net.

Armour Levels

For whatever reason each item of armour will also show up these same statistics but each of the figures will always be set to 0/0/0 and 0-0/0-0/0-0 because they have no attack value. I guess later they may get used for protective statistic details but that is pure guesswork on my part. What you should know is that there are three armour types: helmet; shield; and body armour. There is only one type of helmet but there are four types of shield and seven stages of body armour. Each progression gives you a greater protection with a maximum level of 12 (this takes into consideration your weapons qualities as well). So if you are equipped with the best armour and weapons your defence will maximise out nicely and anyone attacking you would need a seriously big and strong army to defeat you.

The higher the statistics of a weapon or armour the more they cost on the market so if an army's only purpose is to annex countryside then a few hundred men with a basic kit will suffice. If on the other hand you are in this for War and are annexing towns or fighting armies then you'll need a

big army with plenty of high-level equipment and this will cost you a lot!

Research

There are seven different fields that you can make your people study, each field has seven stages. The higher the level the greater the cost and the longer it will take your people to attain that research level, but once you have (and depending on the combination of research you reached) you will be able to make new buildings, bigger and better equipment and sail further (when you have a port and ships). In the early stages be mindful of what you research and build - you don't want to run out of money for the maintenance!

Initially I would recommend researching Natural Science (Biology) and Technics as you will then get better grain production from your granaries which means you can feed more people which in turn puts your population up. In order to do certain things in Tamar you need certain buildings. For example, in order to have more than one scout (which

makes exploring land a lot faster) you need a Town Hall, which in turn requires a Technology level of two, a blacksmiths and a population level of 40,000. For a very good resource regarding weapons and armour statistics, and building requirements visit Captain Garibaldi's homepage at http://website.lineone.net/~bill_hoggett/tamar/Library/

War, what is it good for?

Now in the majority of situations War is a bad thing. However there is usually one thing that war is good for

Research technology and skills to enhance your capabilities.















and that is advancement of things, especially technology. On Tamar there's an extra reason for War - it makes things more exciting. There are players I know in Tales of Tamar who want a quiet, peace-laden existence, but that gets you nowhere and generally it is the well established characters who want peace. Your character ends up stagnating, not able to expand because all land is taken around you. Things become dull. Kill a few of your neighbours (on the orders of an Over-Lord maybe!?), take over their land and you have expanded. Sure you might die and have to restart, you may end up causing a massive world-war or you may end up in stalemate.

The simple truth remains: without action the game is boring and not worth playing. So you cause yourself or your opponent to restart, so what? You may well end up in a better position than you were before. At any rate it's FUN. Go on, make War, not Peace.

Yours in the Tales.
Lords Devery of Eldidd and
Lord Biffordicus of Saxmundham

FORE-MATT Home Computing
(07792) 416254 • Dept. TA, PO Box 835, Wootton Bassett, Swindon, SN4 8RX

We also accept PayPal

 Quake £10	 Quake 2 £30	 Napalm £10	 Freespace £25	 VHI Studio 5.7 £28	 Hyperion Bundle £47
 Simon Sorcerer 2 £35	 T-Zero £15	 Nightlong £25	 S/W Tycoon £30	 FXScan 4 £35	 FXPaint 2 £60 (upg £25)

CDROM GAMES	CDROM GAMES	CDROM GAMES	UTILITIES	UTILITIES	UTILITIES
Adventurers Lair.....£15	Goal! 2000.....£10	Specy Classix.....£10	3DCD-1 Objects.....£5	Cross Mac.....£50	Patchez HD Installers.....£10
Amiga Classix.....£10	Gremlin Classix.....£10	Spherical Worlds.....£10	17 Bit Level 6.....£10	Darkeage Developer.....£10	PFS3.....£35
Amiga Classix 2.....£10	Hell Squad.....£25	Sports Mad.....£20	100%AMIGA Magazine.....£5	Desktop Video Vault.....£10	Photofolio v2.....£25
Amiga Classix 3.....£20	Heretic 2.....£40	Star Fighter.....£15	100%AMIGAAnnualUKsub.....£48	Diavolo 2000.....£50	Red Hat Linux.....£15
Aminet Games.....£15	Imperator CD.....£15	Street Racer CD.....£10	100% Colour Clips.....£10	Digital Makeup.....£15	Science CD.....£10
Aqua.....£10	Isona Collection.....£20	Superfrog.....£10	100% Mono Clips.....£10	Draw Studio 2.....£45	Sounds Terrific 2.....£10
Arcade Classix Mk 2.....£15	Labyrinth Of Time.....£10	Super Methane Bros.....£10	10,000 Amiga Cheats.....£10	Emulators Unlimited.....£10	Source Code Gold.....£10
Blade.....£10	Land of Genesis.....£20	Syndicate CD32.....£15	A-Z of Amiga Games.....£15	Faces of Mars 2001.....£15	System Booster.....£10
Bubba N Stix CD32.....£10	Mad About Mahjong.....£10	Tales From Heaven.....£20	Amiga Developer 2.1.....£20	fxPaint v2 upgrade.....£25	Texture Heaven 1&2.....£10
Bubble Heroes.....£10	Mad About Marbles.....£10	Testament CD.....£10	Amiga Forever 5.....£40	Gateway v1 (netBSD).....£10	Turbo Calc 5.....£55
C64 Classix.....£10	Megaball Deluxe.....£15	Theme Park CD.....£10	Amiga Repair Kit.....£35	GlowIcons.....£10	Turbo Print 7.x.....£40
CDS Collection.....£15	Moonbases.....£10	The Games Room.....£15	Amiga Writer 2.....£35	Glowlcons 2.....£15	Unix Compendium.....£30
Cedric.....£15	Myst (German).....£10	Trivial Pursuit.....£15	Aminet Set 4.5.7 - 12 ea.....£25	Graphic Sensations.....£10	Utilities Experience.....£10
Chess 2k.....£15	Out To Lunch CD32.....£10	Turbo Racer 3D.....£10	Aminet Singles.....£13	Guinness Records v2.....£10	PERIPHERALS
Civilization AGA/ECS.....£10	Pacman Attack.....£10	Ultimate Gloom.....£20	Amos PDCD2.....£20	In To The Net (2CD).....£10	Amiga-TV Scart Lead.....£13
Dragonstone CD32.....£15	Phoenix Fighters.....£10	Ult. Super Skidmarks.....£10	Animations CD.....£15	Learning Curve.....£20	Boing Ball Mouse Mat.....£5
Earth 2140.....£30	Pure Doom.....£10	Uropa 2.....£10	Animatic.....£5	LSD 1 or 2 ea.....£15	MouseIT ser. PC Adaptor.....£5
Earth 2140 Mission Pack.....£15	PuzzleBobs.....£15	Virtual Ball Fighters.....£15	Art Effect 4.....£40	Make CD DAO.....£50	Scanner Targets IT8.7/2.....£10
Eat The Whistle.....£10	Red Mars.....£15	Virtual Grand Prix.....£20	Art Studio Pro.....£35	Meeting Pearls 4.....£10	Serial Link.....£15
European Superleague.....£10	Retro Gold.....£10	Virtual Karting 2.....£10	Artwork.....£10	Moovid Pro 2.....£25	HARDWARE (£5 UK p&p)
Feeble Files.....£35	Seaside.....£20	Vital Light.....£10	Blitz Basic 2.1 (ult.).....£10	Multimedia Backdrop.....£15	Catweasel MK3.....£75
Final Odyssey.....£10	Sensible Soccer CD32.....£15	Wasted Dreams.....£30	Candy Factory Pro.....£40	NodeR.....£30	Deflina Sound Card.....£100
Fightin Spirit.....£10	Shadow of 3rd Moon.....£20	Whales Voyage 2.....£15	Converters Suite.....£10	Network CD.....£10	Deflina Flipper (PCI).....£50
Foundation Und.Land.....£15	Simon the Sorcerer.....£10	Wipeout 2097 PPC.....£10	CybergraphX 4.....£25	Network CD 2.....£15	Subway USB.....£70
Giana Sisters Trilogy.....£10	Sixth Sense Invest'ns.....£15	Word Games.....£10	Cross Dos 7 Gold.....£40	OS 3.9.....£35	(all H/W items special order)

"The Amiga Online Superstore" - Visit our new 128 bit secure online shop at www.forematt.co.uk
Amiga Retro Classics Site: www.forematt.free-online.co.uk EMail: sales@forematt.co.uk

Top Tips

This issue Robert Williams has two longer tips to help you get more from IBrowse - the recently upgraded web browser and Amithlon - the x86 Amiga emulator.

IBrowse MIME Types

MIME stands for Multi Purpose Internet Mail Extensions; it is a standard which was drawn up to define how files of various types could be included within an Internet EMail message. So what, you might reasonably ask, has this got to do with a web browser? When a browser requests a file from a web server, along with the data, the server also sends a header with information about the file. One of the items of information in the header is the type of file which is defined as its MIME type. A MIME type is made up from three components, the type of file (for example image or audio), a forward slash and then the sub type which defines the exact format. For example the MIME type of a JPEG picture is "image/jpeg".

Most web browsers provide users with a method of configuring how the browser will act when it attempts to download a certain type of file. For example options could include viewing the file inside the browser, passing the file to a third party application or saving it to disk. In IBrowse this is configured in the "Preferences/Settings" window's "General/MIME Types" section.

External Programs

If you find a file for download on a website that cannot be viewed within the browser, but is supported by another Amiga program you have installed, it can be nice for that program to automatically display the file when you click on its link. To do this you need to add a MIME Type for the type of file in question and then configure an external viewer. In this example I'm going to set up PDF files (formatted documents commonly found on the web) to be viewed in APDF (Aminet: gfx/show). In the IBrowse "Preferences" window double click on the "General" section; then choose "MIME Types". Click "Add" to add a new type to the list. The first thing we need to know is the correct MIME type for PDF files; the easiest way to find out is to do a quick web search using your favourite search engine. I found this site:

Control over IBrowse's handling at your finger tips.

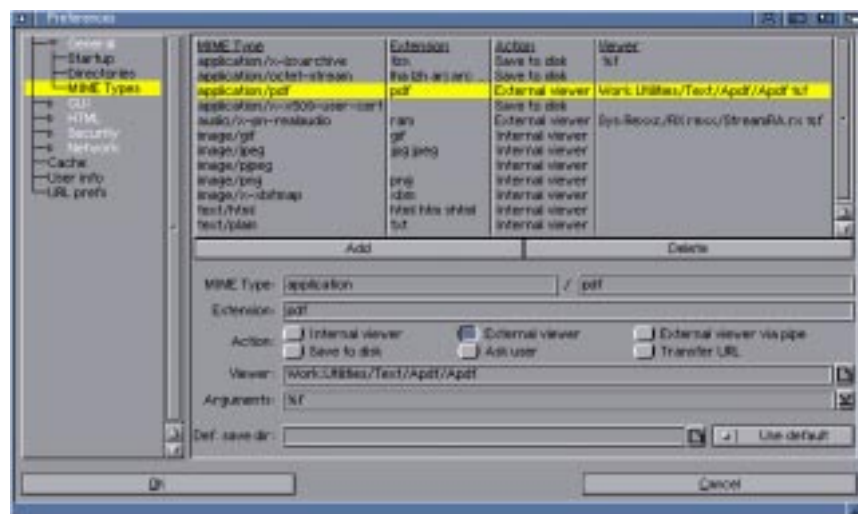

<http://www.ltsw.se/knbase/internet/> which has a useful listing of types. From that we find that PDF is "application/pdf" - in case you're wondering "application" means an application specific file format that doesn't fit a general category.

Enter "application" into the first gadget next to "MIME Type", "pdf" into the second and then "pdf" into the "Extension" gadget. You can enter multiple file extensions separated by spaces if the same format is known by several extensions (.htm and .html is a good example). Note that the important bit to get right is the MIME type itself because this is what IBrowse uses to identify the file format. Now IBrowse can identify a PDF file we can tell it what to do with one should we click on its link. In this case select the "External viewer" radio button; this will cause IBrowse to download the file to a temporary location and then run the program we specify. Using the pop-up file requester select the Apdf program for the "Viewer" gadget. Now we need to get IBrowse to pass the name of the downloaded file as an argument to Apdf; click the select button to the right of the "Arguments" gadget and double click "%f..." in the list. "%f" will be replaced with the name of the downloaded file.

That's all you need to do. Now, when you click on a link to a PDF file, IBrowse will download it and then launch Apdf which will automatically load the file.

Download Directory

Another handy option, which you can set on a file type by file type basis, is the default download directory. This means if you click on a link to a file type set to save to disk, or you force a download from the FAB menu or by pressing Shift, the file requester will point to a directory specific to the file you chose; rather than the default specified in the General/Directories preferences option. I use this because I normally save program downloads (generally lha or lzx archives) into a different directory than my music (mp3 etc.) or picture (jpeg etc.) downloads. To make use of this feature select a MIME type in the list or define a new one and then select a new "Def. save dir". Then, from the cycle gadget to the right, select "Use" to make this the default save directory for this MIME type. With this setting IBrowse will still open a file requester when you download this type of file but it will default to the directory of your choice. If you prefer the save to go straight ahead with no questions select "Use (no req)" from the cycle gadget. Note that even with "no req" selected you will still get a file requester if the name of the file you download is longer than about 30 characters. This is the default file name length limit of the Fast Filing System (FFS). I understand an option may be added to a future version of IBrowse to remove this limit for those using file systems which allow longer file names.

Server vs Extension

You may find that when you click on links to certain types of file you end up with a screen full of gibberish characters, or an IBrowse requester asking what to do with the file, even when you have a MIME type defined. I find this very common with lzx archive files. Normally the only option is to go back to the linking page and force a download with Shift or the FAB menu.

This problem is normally caused by a server not configured to send a MIME type for that file type. LZX files often suffer because they are a less common format and are not configured by default on most servers. To get over this problem you can force IBrowse to deal with the file based on its extension rather than the MIME type. If you don't have a MIME type set up for LZX add one now, the MIME type is application/x-lzx. In the "Extension" gadget enter "!lzx". The exclamation mark before the extension is the important part; it tells IBrowse to let the file extension override the MIME type. Note that in version 2.3 the exclamation mark only seems to work on the first file extension in the list. Now you can specify your viewer options and download directory as normal. If you select "Save to disk" simply clicking on a link to an lzx file should initiate the download regardless of server configuration.

Accessing an Windows hard disk partition from Amithlon

If you are running Amithlon on a PC that also has Windows installed it is useful to be able to transfer files from one system to another without resorting to external media such as ZIP disks, CDs or even floppies. You probably won't be surprised to hear that Windows cannot understand partitions formatted with an Amiga file system such as FFS, SFS or PFS; however the Amiga can read a FAT formatted partition. FAT formats are used by all 9x versions of Windows and Windows Me. Windows NT and XP use NTFS which cannot be read (however there is a work around to this which I'll mention later).

WARNING: Messing about with your hard disk is inherently risky. At the simplest level once you have your Windows partition mounted there's nothing to stop you deleting vital system files by accident. Therefore it's sensible to make a backup of your data before you start following this tip.

Within Amithlon all you need is a copy of the excellent FAT95 file system by Torsten Jager. If you don't have it, download fat95.lha from the disk/misc directory on Aminet and dearchive it. Then copy the file fat95 from the L directory in the distribution to the L directory on your system partition. The next step is to configure a DOSDriver to access your Windows partition. To do this you can use one of the example MountList entries supplied with FAT95 and modify it to your requirements:

Load the file "examples" from the "english" directory into an editor. You should see that it consists of several blocks - each defining a different device

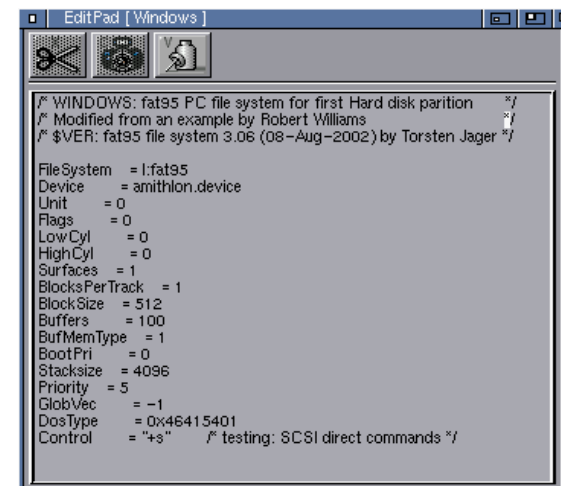

(ZIP:, MS4DD: etc.). The block we are interested in is the last one, ZIP0:. Delete everything in the file down to the last block which starts "/* 100 Mb NEC ZIP...". Now choose "save as" in your editor and save a file called "WINDOWS" (or whatever name you want to give the device when it's mounted) in the Storage/DosDrivers directory in your system partition. Don't close the editor yet, we need to make some further changes to the file.

I will upload a copy of my edited DosDriver to this issue's page on the Total Amiga web site so you can look at a completed example:
<http://www.totalamiga.org/issue15.html>

First delete the line "ZIP0:" because the name for our device will be taken from the file name as mentioned above. Change the "Device" line to read "Device = amithlon.device". On Amithlon all drives attached to the PC, regardless of their connection, are accessed via the amithlon.device. If you have an additional disk controller such as a SCSI card that may be the 2nd.amithlon.device, 3rd.amithlon.device and so on.

Set the "Unit =" number to match the hard disk with the partition you want to mount. If you have an IDE hard disk, unit 0 is master device on the primary channel and unit 1 the slave. Unit 2 is the master on the secondary channel and unit 3 is its slave. On a SCSI system simply use the unit number of the device. If you're not sure what to pick, load up HDTToolBox, select amithlon.device and see what units appear. Remember to look for the lines representing real physical drives (these usually have their manufacturer name in the "Drive" column) not the VirtDsk which is created by Amithlon.

The only other line we need to edit is "DosType ="; this tells the Fat95 which partition to mount. Because the file system understands the master boot record used by PCs to hold their partition information we don't need to

The updated DosDriver based on an example supplied with FAT95.

specify any detailed information, just a reference to the partition we want to mount. Here are some examples from the documentation:

0x46415400 - For floppy drives only.
0x46415401 - The first usable partition.
0x46415402 - The 2nd primary partition.
0x46415405 - The 1st logical drive.
0x46415406 - The 2nd logical drive, etc.

In most configurations your Windows partition will probably be the first FAT partition. If that is the case or you're not sure use "DosType = 0x46415401" and see what gets mounted. Remember that FAT95 will only look for FAT formatted partitions so if you have other partitions for different operating systems they should be ignored. If "0x46415401" mounts the wrong partition or it fails check you have the right device specified then try "DosType = 0x46415402". If you have a more complex partitioning scheme or you want to know more about how all this works take a look at the "readme.too" file in the "english" directory of the FAT95 distribution.

With the DosType set you can now save the finished DosDriver. To test it out open a shell and type:

```
mount devicename:
```

where devicename is the name you gave the DosDriver file. After a few seconds an icon should appear on Workbench; open it and select "Show/All Files" to see the contents of the mounted partition. If the contents are as you expect then that's it. If you've got the wrong partition or no icon appears check your device, unit and dostype settings as described above. To give the DosDriver an icon (this assumes you're using AmigaOS 3.5 or later) open the storage/dosdrivers drawer, select "Show/All Files" and click once on the file you've just saved. Select "Icons/Information" to open the "Intormation" window. Find another DosDriver in the drawer with a suitable icon for the new file and drag the icon onto the icon in the Information window. In the "Default Tool" gadget enter "Mount", click "Save" to close the window. Now the DosDriver has an icon you can either leave it in the storage directory, if you want to access the Windows partition occasionally, or move it to "Devs:DosDrivers/" to have it mount every time you boot into Amithlon.

One final tip, if you have another operating system installed alongside Amithlon such as Linux or BeOS you will find that it can almost certainly read FAT partitions. In that case it can be useful to make a new FAT partition on a hard disk purely to facilitate easy file transfer between operating systems.

Hollywood

Presentation Tutorial

Want to be the star of the show? Why not present your ideas using Hollywood and your Amiga. Robert Williams helps you to make a simple presentation with concepts you can use in your own creations.

If you read my review in issue 14, you know that Hollywood is a powerful multimedia package that works on a wide range of Amigas – something we have been missing for a long time. However, Hollywood is completely script-based and does not have an interface to help you build your multimedia presentation. This gives the user a great deal of flexibility and allows Hollywood to be used for many applications from presentations to simple games and kiosk-type displays. If you're just looking for a multimedia application and don't have any programming experience (anyone with a grounding in BASIC or ARexx should find Hollywood a doddle), you might find a program based on text scripts rather intimidating. Therefore, in this tutorial I will go through the creation of a simple Hollywood script step by step. I have chosen a simple slide show that you might create to accompany a college or work project. While my script will only have three slides, you should easily be able to add more using the same techniques.

As I finish writing this tutorial, I can see it's going to be one of our longest. However, don't let that put you off, as each step is quite simple. You'll find that once you've built up a script like this, you can reuse many parts for your own presentations.

Write your Hollywood script in any text editor, I'm using GoldEd Studio AIX.

```
SEAL: Clubbed/Issue 15/Support/HollywoodTutorial/TutorialScript/tutorial
C:001 L:000001/000102
tutorial.hws
%HOLLYWOOD=1/0
%BGPIC(1)="TutorialBackground_800x600.iff"
%BRUSH(1)="HollywoodGUI_628x223.iff"
%BRUSH(2)="EuroCal_200x198.iff"
%BRUSH(3)="Puzzle_200x158.iff"
%KEYDOWN(1)="ESC"
%CODE
;First slide
SetFont("FreeSansBold.ttf",56)
SetFontColor($000000)
CreateTextObject(1,"Welcome to\nHollywood")
DisplayTextObject(1,CENTER,50)
```

What's Needed

Apart from Hollywood itself, the only other tool you need to write a script is an editor capable of saving standard ASCII text files. Something like EditPad as supplied with AmigaOS is fine. You could use a word processor, but make sure you save in plain text and not the program's own proprietary format. Of course, if you have a favourite, editor just use that; for example, I am using GoldEd Studio AIX, as it's my editor of choice.

It's also handy to have a graphics editing application so you can prepare any images you wish to use in your presentation. Anything with simple functions such as crop and scale will do. If you would like to follow this tutorial using exactly the same images that I am using, they are available for download from the Total Amiga website: <http://www.totalamiga.org/issue15.html>

Getting Started

To get started with the script, it is a good idea to first create a directory on your hard disk where all the files related to the script will be stored. Create the directory anywhere you like, and name it something memorable, like "HollywoodTutorial" for example. Now fire up your editor.

The first section of any Hollywood script contains keyword declarations. Each of these declarations is on its own line starting with a "%" symbol. The section ends with the keyword "%CODE". The first line in the keywords section declares that this is a Hollywood script and that version 1.0 as a minimum is required to run it. You should set the version after the %HOLLYWOOD keyword to the version of Hollywood you are using:

```
%HOLLYWOOD=1/0
```

The next keyword, "%BGPIC", sets the image that Hollywood will use for the background of the presentation. The number in parentheses is used to refer to this particular background image – if more than one is required, you can define "%BGPIC(2)" and so on. After an "=" sign, the filename is entered in quotation marks. If the image file is in the same directory as the script, you do

not need to enter the full path. This is the reason I suggest making a directory and copying into it all the files you use in the script. When Hollywood is running in a window, the size of the window will be defined by the size of the background image. In my case I've made my background 800x600; in this example we're going to use this background for all the slides. Make sure the image file is in your script directory, and enter the following line:

```
%BGPIC(1)="TutorialBackground_800x600.iff"
```

TIP: When writing scripts you'll find yourself doing quite a bit of mental arithmetic because each item is positioned on the Hollywood slide by entering coordinates. I've found that including the size of images in their filenames, as in "TutorialBackground_800x600.iff", is useful because I can see the size of the image by looking at the filename in the script. This is not necessary, however, as Hollywood does not actually use the size in the filename.

Now we're going to load the other images to be used in our script using the "%BRUSH" keyword, which works in exactly the same way as "%BGPIC" except these images can then be placed anywhere on the slide. Note that these images are simply loaded into memory at the start of the script and are not displayed at this point.

```
%BRUSH(1)="HollywoodGUI_628x223.iff"
```

```
%BRUSH(2)="EuroCal_200x198.iff"
```

```
%BRUSH(3)="Puzzle_200x158.iff"
```

Remember that these three files need to be in your script directory. Notice how each brush needs a unique ID number (the one in parens), but it only needs to be unique amongst brushes; the fact that we also have BGPIC(1) won't cause a problem.

It is also possible to load brushes and background pictures during the script. The advantage of loading them in the keywords section is that they are loaded and decoded at the start of the script and are, therefore, available instantly when required. This should make the script play more smoothly on slower



Amigas at the expense of startup time and memory usage.

Later on in the script we will need a way of exiting, so in this headers section we'll declare a key that Hollywood can monitor for presses, in this case the Escape key, using the following keyword:

```
%KEYDOWN(1)="ESC"
```

And that's it – we're ready to start our script proper, so let's end the keywords sections with:

```
%CODE
```

This is a good opportunity to save your script. The standard for Hollywood scripts is to use a filename ending in the extension ".hws". I cannot overstate the importance of saving the script in the same directory as its supporting files.

The First Slide

The first slide will be an introduction to our presentation, so we'll start with a big heading. Before creating the heading text, the font and size it will use must be set. Hollywood can use readily available TrueType fonts, thanks to the ttrender.library or standard Amiga fonts. I'm using TrueType fonts from FreeType. If you want to use these too (or other TrueType fonts), make a directory called "Fonts" inside your script directory and copy the fonts there. Then you can refer to the fonts simply by their filenames and Hollywood will find them. Each Hollywood command takes the form of a function starting with the function name followed by any arguments (options and additional information) it requires in parens. Each argument is separated by a comma. For my heading I'm going to use a bold font in a reasonably large size:

```
SetFont("FreeSansBold.ttf",56)
```

TIP: Find out all the available Hollywood functions and what arguments they take by looking at the Hollywood.guide document in the Hollywood/Help directory.

Now let's set the font colour. I'm using black to contrast with my light-coloured background. Colours are specified using three hexadecimal numbers for red, green, and blue, respectively, just as you would on a website. The colour reference must be prefixed by a "\$" character:

```
SetFontColor($000000)
```

TIP: You can find look-up tables of colour references in the style Hollywood uses in most books on HTML and web design. Similar tables can also be found on the web at sites such as:

<http://www.lynda.com/hexh.html>

Some graphics programs, including fxPaint and Photogenics 5, can also show you the reference for any colour in their palettes.

We'll make our heading as a text object - this will enable us to place it anywhere on the slide. As with the brushes, the text object has to have an ID number, which is the first argument, followed by the text required in quotation marks:

```
CreateTextObject(1,"Welcome to\nHollywood")
```

There are two points to notice in the above text. Experienced C programmers will recognize "\n", which inserts a new line; breaking the text onto two lines. Also, note the space after the new line. I included this because Hollywood does

The first slide in our presentation. The overall size is set by the image used for the background.

not have an option to centre lines of text; the extra space centres "Hollywood" under "Welcome to" nicely with the font I'm using.

Just like the brushes, at this point all we have done is create our text object in memory; it is not yet displayed. The "DisplayTextObject" function will actually show it on the slide. To use this function, we must tell it which text object we wish to display along with the X and Y coordinates of its top-left corner. We know we want text object ID 1, and it's easy to decide the Y position (that's the distance in pixels from the top of the slide), but how do we know the X position when we don't know how wide the text will be? If we want the object to be centred on the slide (or at one edge), it's easy because we can use one of Hollywood's built-in constants. These constants cause the program to work out the position for you based on the size of the object. I think the heading would look good centred, so we'll use the "CENTER" constant for the X coordinate like this:

```
DisplayTextObject(1,CENTER,50)
```

Below the heading we can display one of our brushes; in this case it's a picture of the Hollywood interface. Because we have already loaded the brush with a keyword, we just need to issue the "DisplayBrush" function to display it in the desired position. Using DisplayBrush will cause the image to pop onto the screen in the position specified. That's a bit boring, so let's make the brush fade in using the "DisplayBrushFX" function. This works in the same way but adds the effect; Hollywood has over 50 to choose from. I'm going to use CROSSFADEPRECALC, which will make the image smoothly fade in; "precalc" means that the fade is calculated first and then displayed so it is smooth on slower machines. So here is the line to enter:

```
DisplayBrushFX(1,CENTER,250,CROSSFADEPRECALC,10)
```

As with the "DisplayTextObject" command, we need to specify the brush ID, X coordinate, and Y coordinate. The other two arguments are the transition effect and the transition speed, "1" being the slowest.

TIP: When starting to write a script, I find it easiest to guess the positions for each object, getting them roughly right in relation to each other. After playing the script in Hollywood I then tweak the coordinates to get everything positioned exactly as I want it.

To finish off this slide, we'll have another line of text below the image. This is

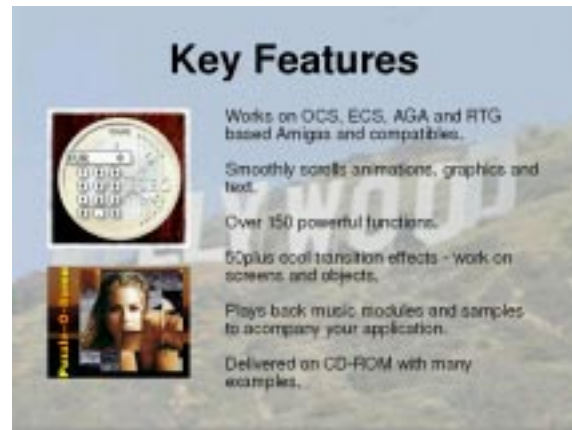

done in exactly the same way as the heading except we'll have a plain font and a smaller size. Notice that I don't need to set the text colour again, as it's not changing:

```
SetFont("FreeSans.ttf",18)
```

```
CreateTextObject(2,"A powerful multimedia scripting engine for your Amiga!")
```

```
DisplayTextObject(2,CENTER,480)
```

If we run this script now, Hollywood will close its window. As soon as the script has finished, we need to add a command that will make it wait:

```
WaitLeftMouse()
```

As you might guess, with this command Hollywood will wait until you click the left mouse button until going to the next command. As there currently is no next command, the script will end on a mouse click.

With the first slide completed, we can give our script a try. First make sure the script is saved to disk (you don't have to quit the editor), then load up the Hollywood "GUI" program. When the window opens, click "Settings" and choose "No" to a borderless window and "Yes" to open on Workbench. Now click "Display" and use the file requester to select your script file to play. After a few moments, while the background and brushes are loaded, a new window should appear, and the text and brush objects will be displayed as you scripted. When you've had a look, click the left mouse button to close the window. If an error occurs, Hollywood should give a message telling you in which function and line it is located. In that case, go back to your editor and carefully check the line specified.

At this point you will probably want to look at the slide carefully and make adjustments to the positioning of the objects and the layout of the text in the script. I find this tends to be an iterative process: often it can take several tests to get everything just right.

The Second Slide

Before we can start the next slide, we need to clear the first – to do this we use the "DisplayTransitionFX" command. This can change to a different background image using a special effect. In our case if we specify the same background image (ID 1) again, it will just clear the slide for us with an overall effect. I've chosen the "BARS" transition; feel free to experiment with the others mentioned in the documentation. This function requires the ID, transition name, and speed as arguments:

```
DisplayTransitionFX(1,BARS,1)
```

In the same way as we did for the first slide, let's add a big bold heading at the top of the second slide:

```
SetFont("FreeSansBold.ttf",56)
```

```
CreateTextObject(3,"Key Features")
```

```
DisplayTextObject(3,CENTER,50)
```

Notice that even though we've cleared the slide, we still need to keep the IDs of each object unique throughout the presentation. Therefore, this heading is TextObject ID 3.

The main content of this slide is going to be a text list of features. However, it's always nice to brighten a slide like this with some images. Brushes 2 and 3, which we loaded in the keywords section, are screenshots of Hollywood that would be good for this purpose. To add a bit more interest, instead of having them appear in their positions, let's make them scroll in from the edge of the screen using the "MoveBrush" function. We have to call the function separately for each brush specifying its ID number, start X and Y coordinates, finish X and Y coordinates, and finally the desired move speed. As we would like the brushes to appear from the left-hand side of the slide, we need to specify the start coordinates outside the slide. To do this we can again use a constant built into Hollywood. By specifying LEFTOUT as the starting X coordinate, Hollywood will calculate a value based on the size of the brush, so the brush will be just out of view when the move starts. In the example function lines below I have set the finishing coordinates based on the size of the images and where I want the text to appear. Keep the Y coordinate the same for both the start and finish positions so that the images will scroll in horizontally:

```
MoveBrush(2,LEFTOUT,145,50,145,15)
```

```
MoveBrush(3,LEFTOUT,368,50,368,15)
```

TIP. When working out the positioning for these functions, I'm sure you can see

how useful it is to have the size of images recorded in their file names. I also find it handy to have a calculator utility running next to my editor for quick calculations. If you're working on a more complex slide than the ones in this tutorial, you may find it helpful to sketch it out and note the pixel dimensions on the sketch.

This slide is going to have a larger amount of text on it than the first one, so rather than creating lots of text objects that then have to be placed, we'll use an alternate method. The "Print" function displays the text you specify on the slide within user-definable margins. Text is automatically wrapped to fit the margins, and you can use tabs to create simple tables. Another advantage is that if you're using TrueType fonts, text created with the "Print" function will be antialiased, giving it a smooth unpixelated appearance.

First we'll set the margins between which the text will be displayed. Hollywood only allows you to set left and right margins; both are specified from the left-hand side of the slide in pixels using the "SetMargins" command:

```
SetMargins(300,750)
```

Notice that I have set the left margin to be wide enough so the text will avoid the two 200-pixel-wide brushes.

Rather than setting a top margin, we can use the "Locate" function to move the point at which the text will appear when we print to the correct vertical position. "Locate" takes the X and Y coordinates as two arguments. Set the X value to 0 because we've set the left margin anyway and the Y value to 145, so the text starts at the top of the brushes on the left:

```
Locate(0,145)
```

Print uses the font, type size, and colour in the same way as CreateTextObject, so the next function just has to set the font and size required:

```
SetFont("FreeSans.ttf",24)
```

Now we can print the first paragraph with one function line because Print only takes one argument, and that is the text to be displayed enclosed in quotation marks. The positioning is controlled by the margins and the "Locate" statement we've just issued. If you don't place a new line code ("\n") at the end of each printed line, it will carry on immediately after the last line printed. In our case we want a blank line between each paragraph, so we need two new lines at the end of each one:

```
Print("Works on OCS, ECS, AGA and RTG-based Amigas and compatibles.\n\n")
```

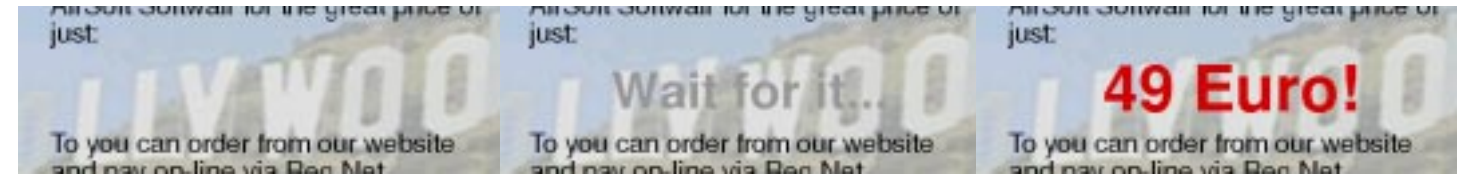

```
Print("Smoothly scrolls animations, graphics, and text.\n\n")
```

```
Print("Over 150 powerful functions.\n\n")
```

```
Print("50-plus cool transition effects - work on screens and objects.\n\n")
```

```
Print("Plays back music modules and samples to accompany your application.\n\n")
```

```
Print("Delivered on CD-ROM with many examples.\n\n")
```

TIP. If you want to make paragraphs of text appear one at a time on a mouse click, simply place a "WaitLeftMouse()" function between each "Print" function.

As you can see, issuing those commands was much quicker to code than creating multiple text objects. We didn't have to worry about manually wrapping lines that were too long to fit.

That's another slide done, so just add a "WaitLeftMouse()" function at the end:

```
WaitLeftMouse()
```

Then load it into Hollywood to try it out. As before, make any adjustments required. One aspect to check is the speed of the transitions and move functions. Depending on the speed of your Amiga and your tastes, they may need speeding up or slowing down. Generally the lower speed settings are slower and the higher faster. With some effects, you may find the maximum

speed is limited by the power of your Amiga.

The Third Slide

This is the final slide of this tutorial, and as we've got some of the basics out of the way, we can add a few more interesting and advanced features. As before, clear the previous slide with a "DisplayTransitionFX" function:

```
DisplayTransitionFX(1,BARS,1)
```

TIP. Try to avoid using too many different transitions and effects in a single presentation, since it tends to look over the top and unprofessional. Instead, stick to two or three well chosen effects, and they will help make the presentation more interesting but still look consistent.

Next add the heading, again using the same commands as the previous two slides:

```
SetFont("FreeSansBold.ttf",56)
```

```
CreateTextObject(4,"How to Order")
```

```
DisplayTextObject(4,CENTER,50)
```

We'll add the main text to this slide using "Print" functions because there's quite a lot of it. Notice that in the middle of the first paragraph I've added several blank lines, which are for something coming up a bit later.

```
SetMargins(150,650)
```

```
SetFont("FreeSans.ttf",30)
```

Above: Locate(0,145)

creating a simple "animated" effect like this one is easy. Print("Hollywood can be purchased from AirSoft Softwair for the great price of just:\n\n\n\n")

Print("You can order from our website and pay online via Reg.Net.\n\n")

Print("There isn't a demo version of Hollywood, but you can download a promo package of screenshots.")

When you're making a presentation, it can be nice to reveal parts of the slide as you're talking about them. In this case I thought it would be fun to play a bit of a trick when revealing the price of Hollywood and, surprise surprise, it also lets me show you another useful function! After a click we'll display the text "Wait for it..." in the space after the first paragraph, and then we'll wait for another click before erasing that and displaying the real price.

To start, we need to create the two text objects defined as before. I've chosen a medium grey colour for the "Wait for it..." and a bright red for the actual price. Both are in a bold font, but the price is slightly bigger:

```
SetFont("FreeSansBold.ttf",56)
```

```
SetFontColor($999999)
```

```
CreateTextObject(5,"Wait for it...")
```

```
SetFont("FreeSansBold.ttf",72)
```

```
SetFontColor($DD0000)
```

```
CreateTextObject(6,"49 Euro!")
```

Remember that the objects are created but not displayed at this point. Before that happens, we want to wait for the presenter to click the mouse button:

```
WaitLeftMouse()
```

Now we display "Wait for it..." normally using a nice crossfade. For a small object like this, you can get away without using "CROSSFADEPRECALC" on most systems:

```
DisplayTextObjectFX(5,CENTER,260,CROSSFADE,5)
```

Now wait again until the presenter is ready to display the price:

```
WaitLeftMouse()
```

Now here's the new command. "Undo" and "UndoFX" remove the selected object from the slide. "UndoFX" allows you to specify a transition effect so you

The final slide complete with "animated" section and "interactive" URL.



can fade it out as we are about to do. I suggest you set the fade on the "UndoFX" to a faster speed than the DisplayTextObject commands to give them more impact:

```
UndoFX(TEXTOBJECT,5,CROSSFADE,10)
```

Now we just display the price using a standard command:

```
DisplayTextObjectFX(6,CENTER,250,CROSSFADE,5)
```

You will almost certainly need to test and adjust the positioning of the text objects so they fall in the space between the paragraphs. In case you are wondering, we had to use text objects because text generated by the "Print" function can only be removed by clearing the whole slide.

Interaction

So far our presentation has been a simple slideshow with no more interaction than an occasional click of the mouse button. Hollywood is capable of much more than that, and although this tutorial is designed to be simple, I thought I would give you a little taster. I hope this will whet your appetite for experimentation and perhaps a more advanced tutorial in the future.

At the end of the presentation we refer to a website. It would be quite cool if there were a link in the presentation that would open the website in a browser. Fortunately, Hollywood is able to run external commands, so this is no problem. "But how is the presenter or the person viewing the presentation going to launch the browser?" I hear you cry. Well, why not have a link to click at the bottom of this particular slide?

In Hollywood, areas of the slide that can be clicked to produce an action are completely independent of the objects displayed on the slide. You cannot load a brush or create a text object and say "make that a button." First you need to display the object and then define a button covering the same area. So our first job is to display the text that will become the hyperlink. We can do this by using a text object as normal. To give the user a clue that this is a link, the URL will be blue in contrast to the rest of the text:

```
SetFont("FreeSans.ttf",24)
```

```
SetFontColor($0000DD)
```

```
CreateTextObject(7,"http://www.airsoftsoftwair.com/")
```

```
DisplayTextObject(7,CENTER,550)
```

Next we need to define a button to cover the same area. Unfortunately, in Hollywood there's no way that I can find

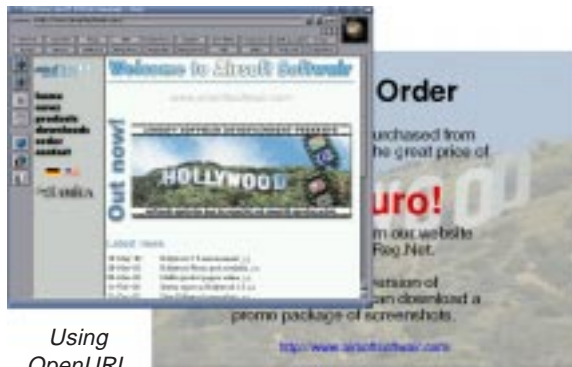

Using OpenURL our simple presentation can even be enabled with the browser configured by the user.

to get the position of an object, and as we've used the "CENTER" constant, we don't know the exact X position. However, we do know the Y position (550), and we can find out the height. Therefore, it is easiest to define a button that stretches the width of the display but is the correct height and is in the correct vertical position.

First we use the "GetAttribute" function to find out the height of the text object and store it in a variable called "buttonh." The function arguments are the type of object we want information about (it's a TEXTOBJECT), the object ID and the attribute required (ATTRHEIGHT):

```
buttonh = GetAttribute(TEXTOBJECT,7,ATTRHEIGHT)
```

The "CreateButton" command wants the position of the lower edge of the button counted from the top of the slide in pixels, so we need to add the position of the top of the text object to "buttonh". Hollywood cannot evaluate traditional mathematical expressions, such as "21 + 47," so we need to use the "Add" function like this:

```
buttonb = Add(550,buttonh)
```

This stores the total of 550 added to the contents of buttonh in the variable buttonb. Finally we have all the information we need to create our button (that is, the hot spot that will sit over the text we displayed). The "CreateButton" command needs arguments to specify the button ID, the X and Y coordinates of the top-left corner, followed by the coordinates of the bottom-right corner:

```
CreateButton(1,0,550,800,buttonb)
```

TIP: If you want to have buttons on every slide in your presentation, you can define them in the keywords section using the "%BUTTON" keyword. Remember, this defines the hot spot; you will need a visual clue in that area so the user knows where to click.

Before we go on to think about what will happen when someone clicks in the button area, there's one more thing we need to set up. We have to tell Hollywood to wait and check for a mouse click. To do this, we'll use the

following lines:

```
While(quit=FALSE)
```

```
WaitEvent
```

```
Wend
```

The "WaitEvent" function waits for the user to perform a defined action and then jumps to the commands defined for that action. In our case, we have two actions defined. One action is the button we have just created, and the other is the "Escape" keypress we defined right at the start in the keywords section. The "While" and "Wend" lines cause Hollywood to go back to the "WaitEvent" command after an event has taken place, but only while a variable called "quit" contains the value "FALSE". This means we can break out of this loop by setting the "quit" variable. If none of that makes sense to you, don't worry – just put it into your script, and it will allow your buttons and keypresses to work.

Now we need to add two more sections of code that will define what Hollywood does when the "Escape" key is pressed and when our button is clicked. First we need to add this line to our script:

```
End
```

"End" signals the end of the main script. After that, we can add the additional sections called "subroutines." Each subroutine is identified by a "Label" function, which is its first line. Subroutines executed by a button click or a keypress have special names so Hollywood knows where to jump to. Our button is ID 1, so we need to create a subroutine called "OnButtonClick1". After the "End" function, enter the following line:

```
Label(OnButtonClick1)
```

When the user clicks button 1, we want our browser to open and display the URL "http://www.airsoftsoftwair.com/". To do this, we're going to use Hollywood's "Run" function. Run is used to execute an AmigaDOS (shell) command asynchronously. (That means the Hollywood presentation can continue or even quite while the shell command is still running.) Hollywood can execute any shell command (and remember most Amiga programs can be run from the shell). In this example, we're going to use OpenURL, which loads a URL into the web browser the user has configured. The Run function is simple; the only argument is the command you want to run enclosed in quotation marks:

```
Run("openurl http://www.airsoftsoftwair.com/")
```

NOTE: For this function to work, you will need the OpenURL package installed on your Amiga and configured

to start your web browser of choice. If you don't have it, OpenURL can be downloaded from Aminet, comm/www/OpenURL44.lha.

TIP: You can test your Run command by entering it into a shell window and pressing Return. If all is well, it should work inside Hollywood.

Hollywood handles mouse clicks at quite a low level. This means it can easily pick up multiple presses for one click. To prevent this situation, we need to add the following function:

```
WhileMouseDown
```

That's all there is to handling the mouse click. Now complete the subroutine and return to the

main script with this function:

```
Return
```

Now we'll do the final part of our script. If we were running Hollywood full-screen or in a window without a border, there would now be no way to exit the script. Let's give ourselves the option to exit using the "Escape" key. We have already defined this as a key to monitor using the "%KEYDOWN(1)" keyword. Pressing "Escape" while in a "WaitEvent" will cause Hollywood to jump to an "OnKeyDown1" subroutine. So let's create one:

```
Label(OnKeyDown1)
```

All we need to do in this subroutine is set the variable "quit" to "TRUE". Now when we return to the main body of the

script it, will jump out of the "While"... "Wend" loop and exit the script. Therefore, the final two lines are:

```
quit=TRUE
```

```
Return
```

Th-th-th-that's all, folks!

Now save your script and load it into Hollywood to see the results. Notice that on the last slide you can't click to end the presentation any longer. This is because you need to be able to click the URL. Instead, try pressing Escape. The window should then close.

If you've got this far through the tutorial, well done! I hope you found it useful. I also hope that some people who were put off by

Hollywood's script-based design will read this and decide to give it a go. If you want to take it further or want to try making your own presentation, a good way to start is to modify this script. You can simply copy a block containing a complete slide (remember to include the "DisplayTransitionFX" line between slides) and customise it to your needs. Try loading the different brushes and experimenting with text styles and positioning. To achieve different effects, look up the functions we used in the documentation to find out what other options they have. Again, I have some ideas for a future tutorial that would be based on an interactive kiosk type application. If you would like to see that, please drop me a line: robert@seal-amiga.co.uk.

Next Issue

Coming up in Total Amiga issue 16:

News

- All the latest news on AmigaOS 4 and the AmigaOne.

Reviews

- Hollywood 1.5.
- Algor USB with Flash ROM.
- Spider II USB on Amithlon.
- MorphOS 1.4 Update.
- Amiga Arena games collection.

Support

- Enhancing scanned images tutorial.

Regulars

- P D Paradise
- Top Tips

Plus much more!

The new issue is due in:

October 2003

Note: Total Amiga is produced by volunteers and this means sometimes issues run late. If you're concerned about the status of the next issue please take a look at <http://www.totalamiga.org> or contact us by EMail or phone (details inside the front cover).

Total Amiga Mailing Lists

Kee up to date with our progress with new issues of Total Amiga and get news of website updates and previews of the content of new issues by joining the Total Amiga announcements mailing list. This list is only posted to the editor so your mail box won't be flooded. Expect a maximum of 4 or 5 messages a month, as a minimum we post a monthly update.

To join just send a blank EMail (no subject or body text is required) to: totalamiga-announce-subscribe@yahooogroups.com

We also have an open discussion mailing list where you can chat to other readers and talk to members of the total Amiga team. The subscription address for this list is: totalamiga-subscribe@yahooogroups.com

Subscribe to Total Amiga

To subscribe to Total Amiga please complete this order form and send it with the appropriate payment to: (If you don't want to cut your magazine a photocopy is acceptable or just include the details below on a piece of paper) Total Amiga, 26 Wincoat Drive, Benfleet, Essex, SS7 5AH. Payment can be by cheque or postal order (in pounds sterling made payable to **South Essex Amiga Link**) or in sterling cash (at your own risk).

Full Name:	<input type="text"/>	Tel.:	<input type="text"/>
Street Address:	<input type="text"/>	User Group:	<input type="text"/>
Post Code:	<input type="text"/>	Please tick what you require:	
Country:	<input type="text"/>	A four issue subscription to:	Back issues:
EMail:	<input type="text"/>	United Kingdom (£14) <input type="checkbox"/>	Total Amiga 13 (£2.50) <input type="checkbox"/>
		Europe (£17) <input type="checkbox"/>	Total Amiga 10 (£2.50) <input type="checkbox"/>
		Rest of the World (£20) <input type="checkbox"/>	Clubbed 8 (£2.50) <input type="checkbox"/>
		Start subscription from issue no. <input type="text"/> (Leave blank to receive the next issue)	

AmigaOS 4.0: New Screen-shots

These screen-shots are said to show AmigaOS4's default GUI look which is currently about 80 percent complete. Below: The new OS 4 PDF viewer in action.

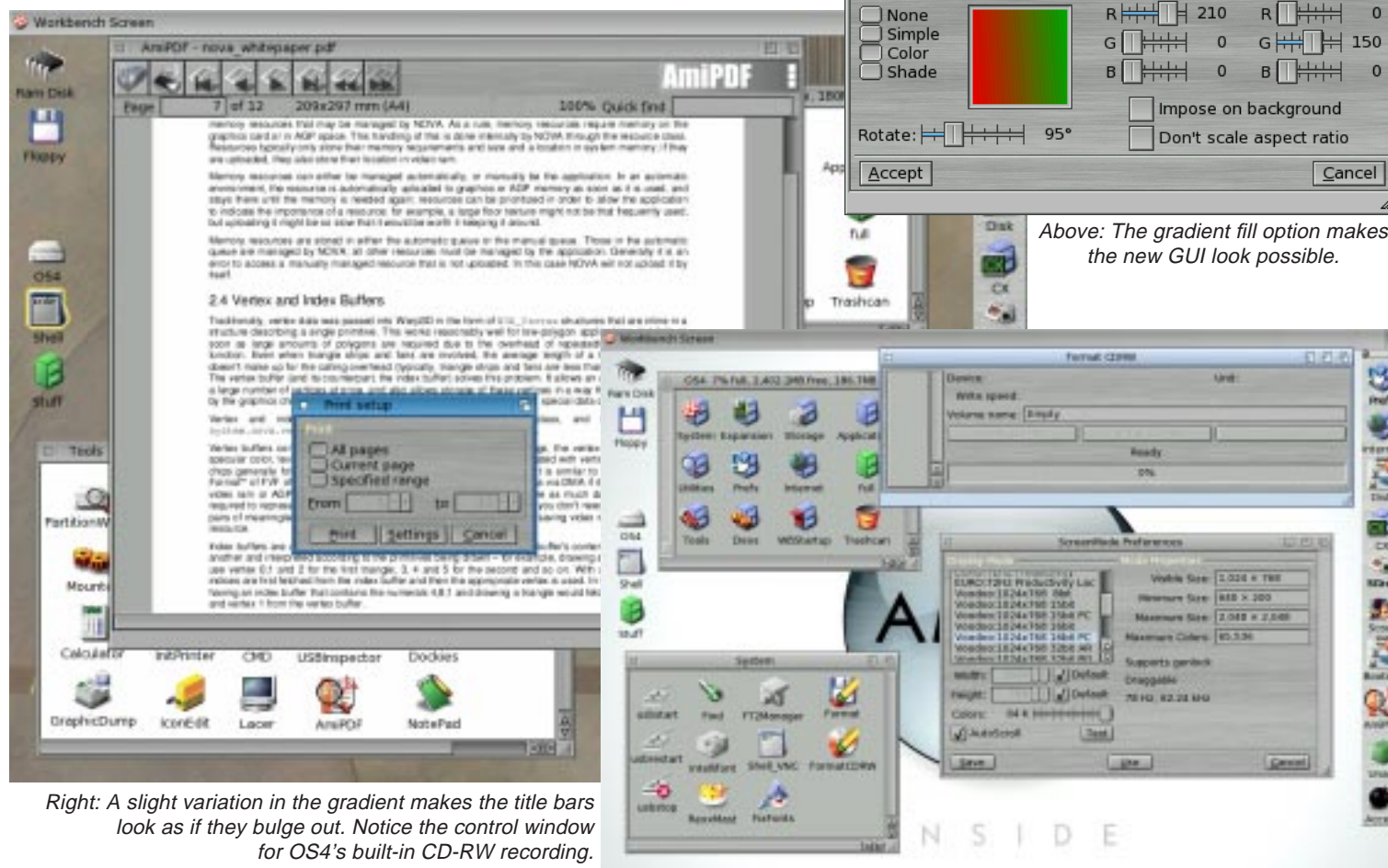

Above: The gradient fill option makes the new GUI look possible.

Right: A slight variation in the gradient makes the title bars look as if they bulge out. Notice the control window for OS4's built-in CD-RW recording.

fxPaint 2 (Reviewed on page 32)



Above: Paint on custom gradients in any shape.
Bottom: An HTML album generated with fxAlbum and the supplied "Dropshadow" skin.

MorphOS (Reviewed on page 22)



Above: A colour screen-shot of Sam Byford's MorphOS 1.3 desktop.

Left: Birdie Shoot, the addictive game supplied with new Pegasos motherboards.